

Montageanleitung

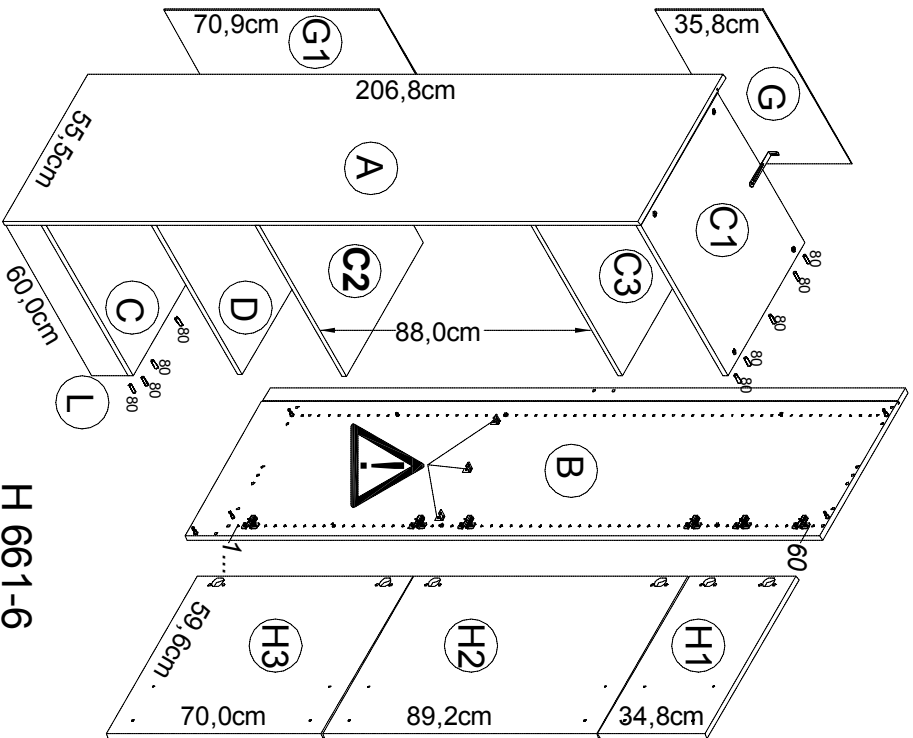

Service-Hotline
01805-678101
0,14€ pro Min.
+ +49 für Österreich
Auslandstarif pro Min.
service@opfitfit.de
voor Nederland en België
00800-40119350
benelux@opfitfit.de

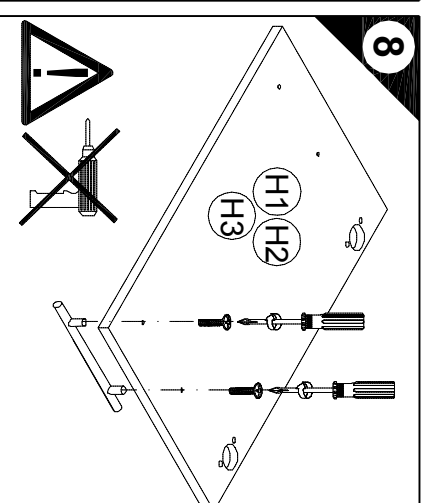
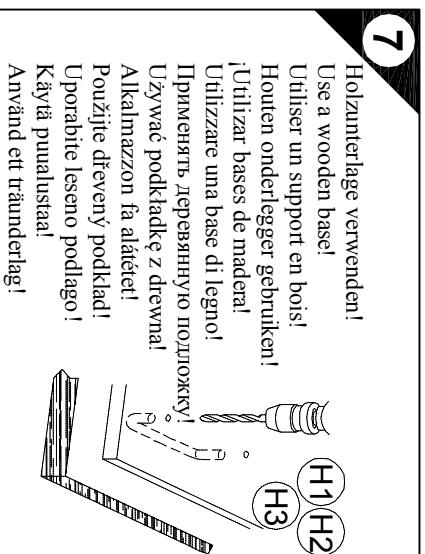
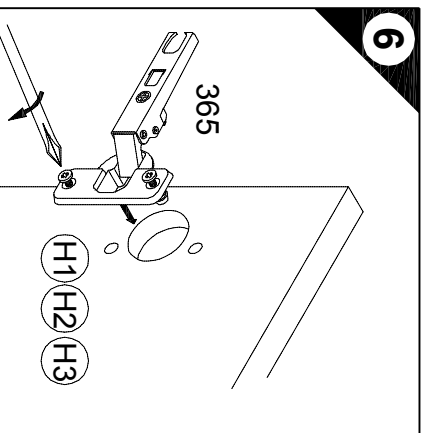
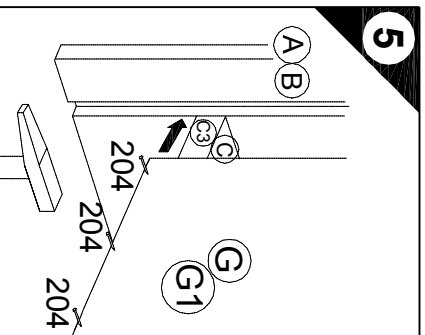
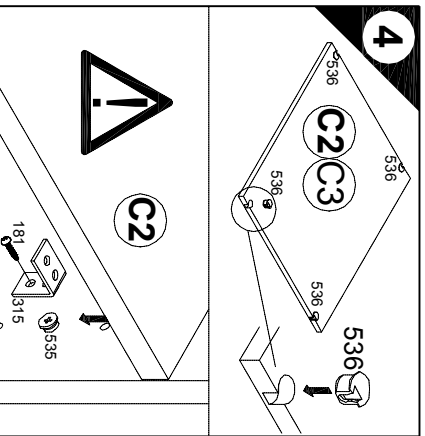
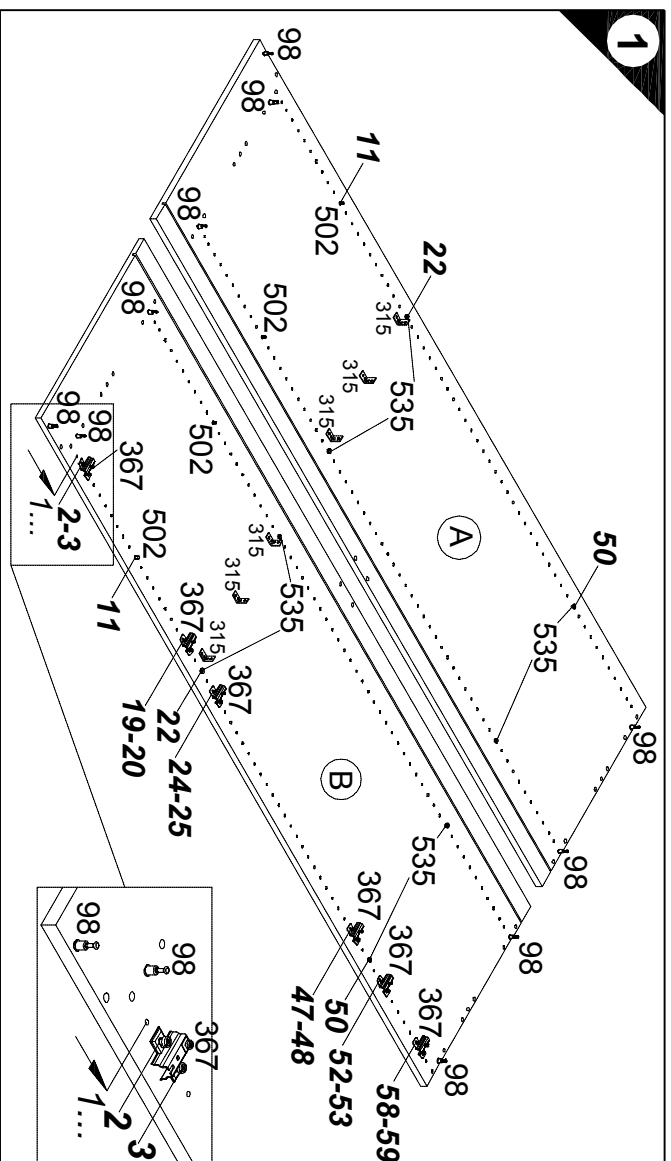
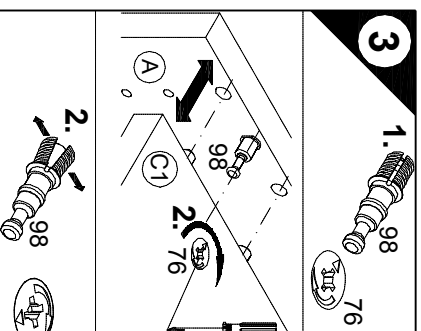
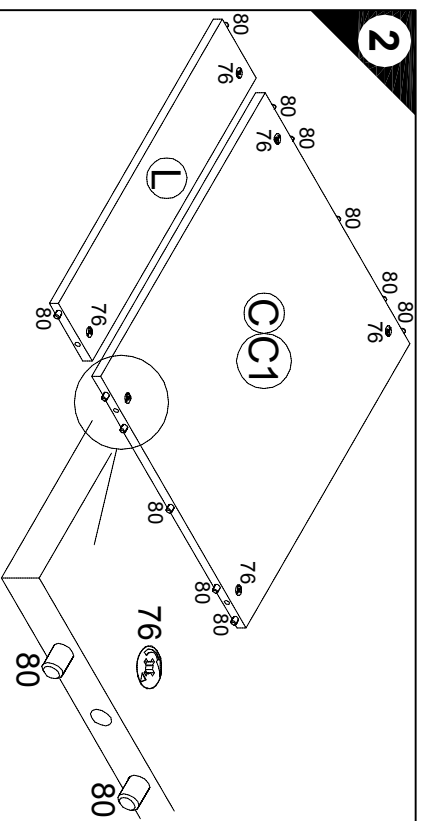
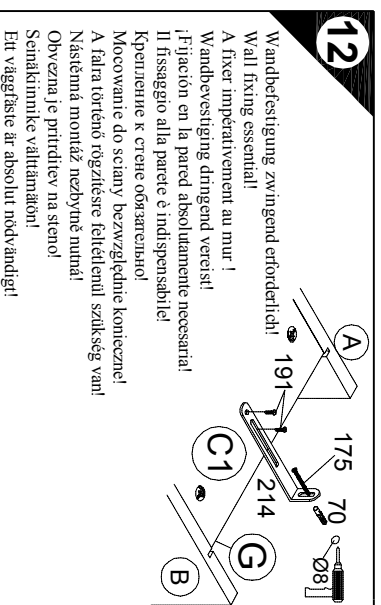
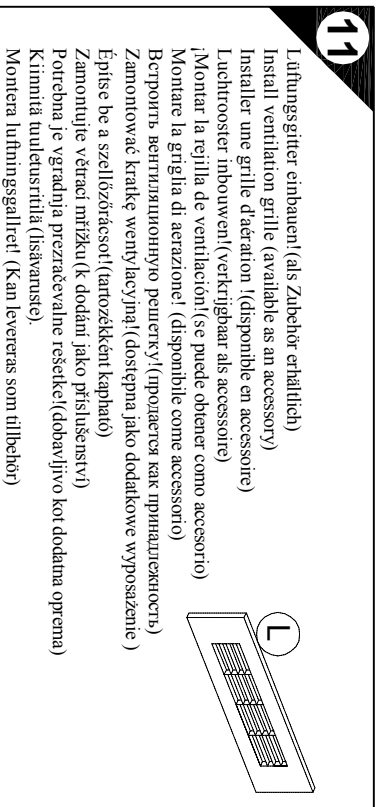
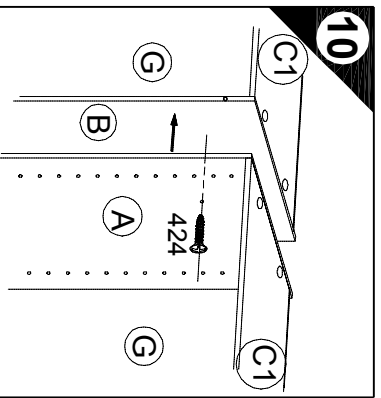
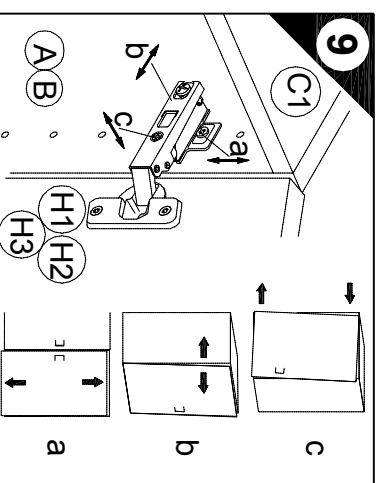
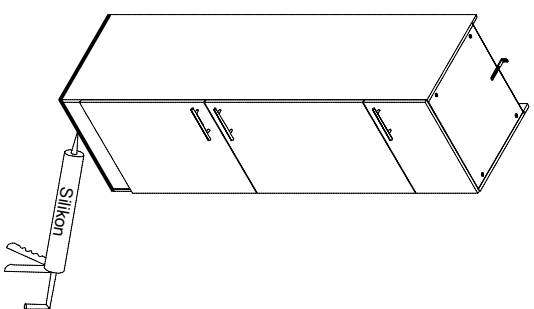

9

10

11

12

4

5

6

7

8

C1

C1

C1

A

A B

H1 H2 H3

C1

C1

A

a

b

c

a

b

c

a

b

c

a

b

c

Ersatzteile/ Spare parts/pièces de rechange/Reserveonderdelen/Piezas de recambio/Ricambi/Zapascnye чacти/Części zamienne/ρόtalkingatészék/Náhradní části/Nadomestni deli/vaosaosaf/reservdelar
60cm H661-6

A E961011 B E961012 C E954223

H1 E980556 H2 E940605 H3 E940621 D E970973

G E950223 G1 E950223 G2 E950223 G3 E950223 G4 E950303 G5 E970090 G6 E970109

500584.2.B 08/12 SI

S E R V I C E K A R T E

VH

Liebe Kundin, lieber Kunde,

obwohl wir unsere Möbel vor der Auslieferung einer eingehenden Endkontrolle unterziehen, kann es vorkommen, dass einmal ein Zubehörteil fehlt oder während des Transports beschädigt wird. Senden sie den Artikel bitte nicht zurück, sondern fordern sie einfach Ersatz für das Einzelteil bei unserer Kundenhotline an. Die Telefonnummern finden sie auf den Serviceseiten im Katalog.

Bitte benennen sie die Teile wie sie auf ihrer Aufbauanleitung angegeben sind. Fügen sie auch **Artikelnummer, Modellnamen und Farbnummer** bei. **Siehe Beispiel.**

Wir werden ihre Anforderung sofort bearbeiten und ihnen das Ersatzteil umgehend zusenden.

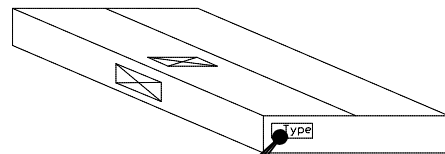
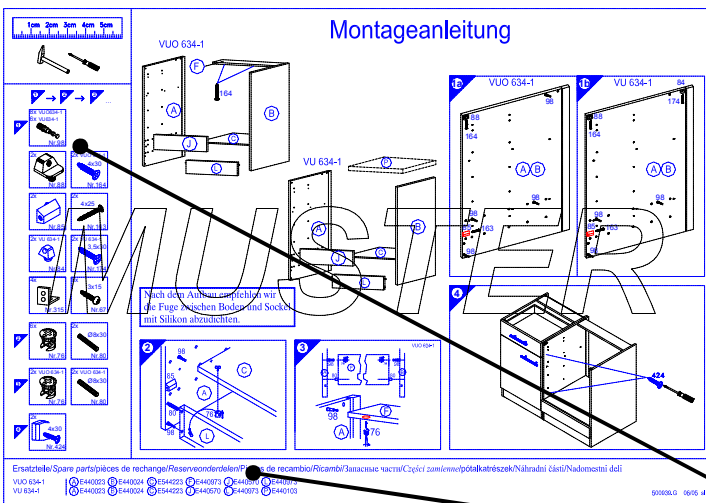

Muster - Bestellung		
Artikelnummer	123 456	
Modellname	Unterschrank VU634	
Farbe	TA 01	
Benötigte Ersatzteile:		
Bezeichnung	Nr.	Anzahl
Beschlagteil	98	2
Teil B	E 440 023	1

Bitte entnehmen sie die notwendige Ersatzteilnummer der Aufbauanleitung die zum Möbel gehört!

Kundendaten	
Kundennummer	
Name	
Vorname	
Strasse	
Haus-Nr.	
PLZ	
Ort	
Rechnungsdatum	
Tel. für Rückfragen	
Notizen:	

Ersatzteilbestellung		
Artikelnummer		
Modellname		
Farbe		
Benötigte Ersatzteile:		
Bezeichnung	Nr.	Anzahl
Grund der Ersatzteilanforderung:		