

Modell: CITY / GIRON 27

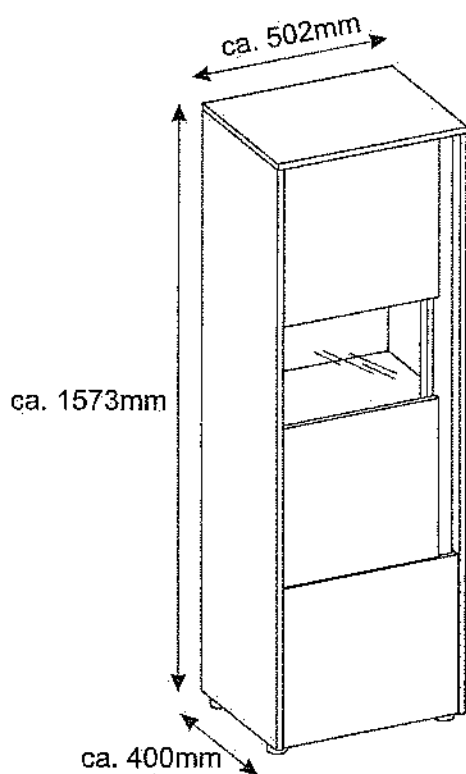

- Ⓛ Montageanleitung
- ⓃL Handleiding voor de montage
- ⓂR Montaj talimatı
- Ⓛ Notice de montage
- ⓃZ Montážní návod
- ⓂU Szerelési útmutató
- ⓂE Assembly Instructions
- Ⓛ Instrukcja montażu
- ⓂU Инструкция по монтажу
- ⓂT Istruzioni di montaggio
- ⓂK Návod na montáž
- ⓂO Instrucțiunile de montaj
- ⓂS Instrucciones de montaje
- ⓂR Montaj Talimatı

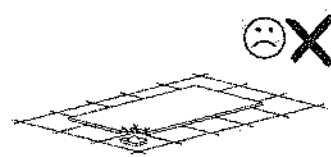

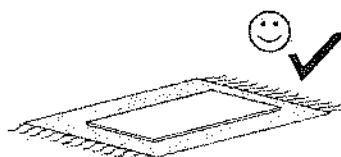
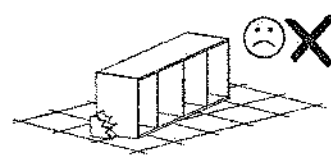
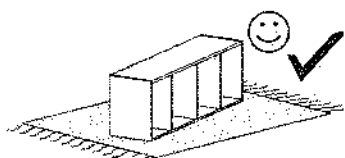
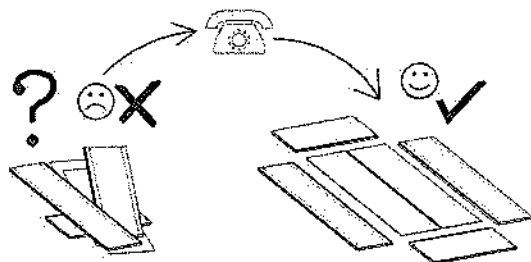
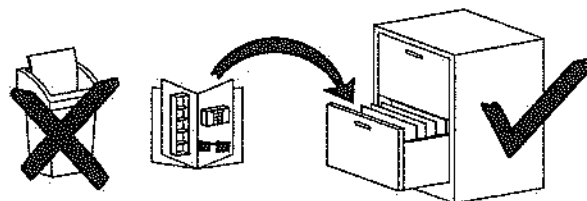
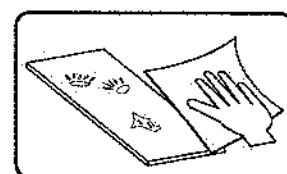
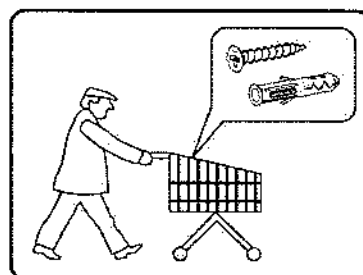
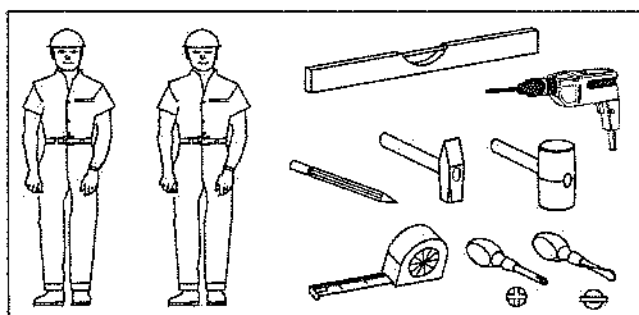
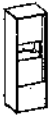



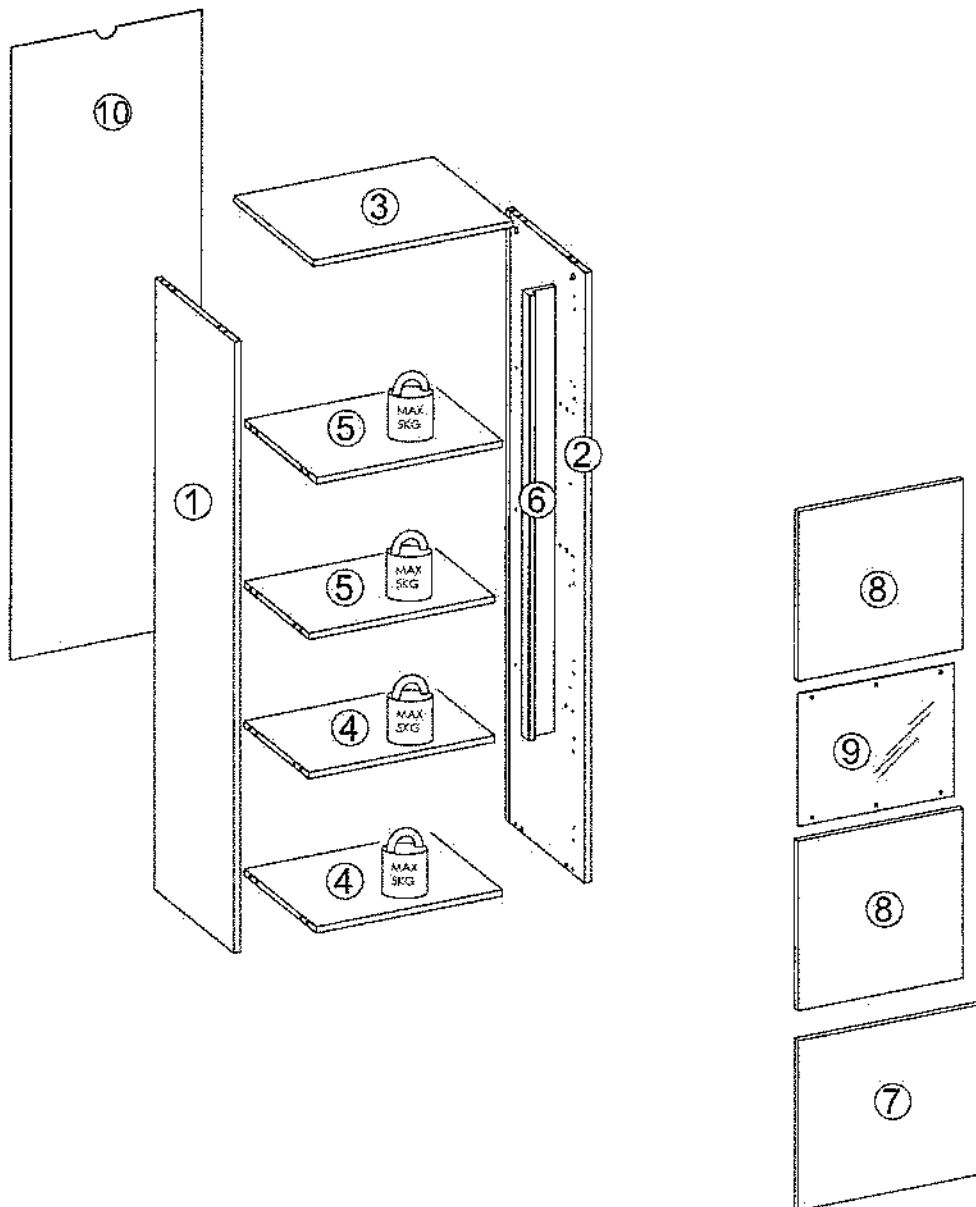

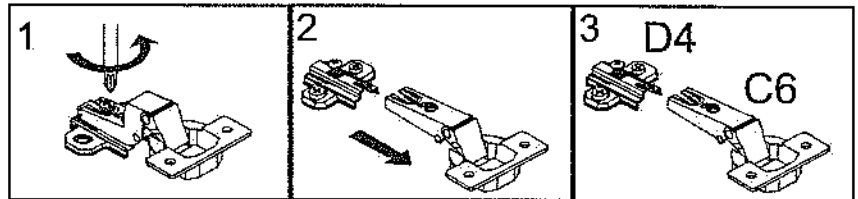
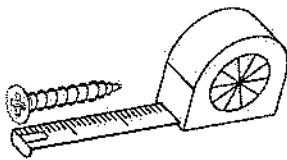
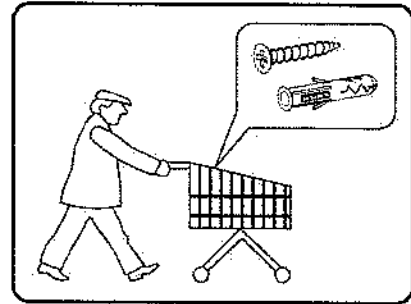
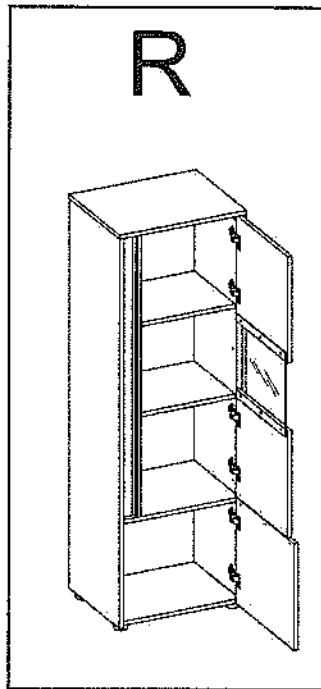
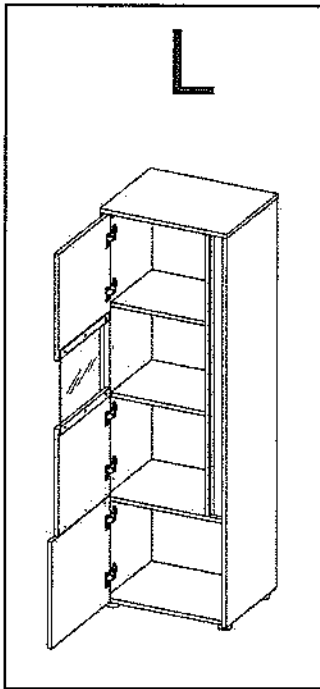







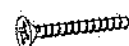

n°	L[mm]	B[mm]	T[mm]	Menge	Coll.
1	1532	400	16	1	1/1
2	1532	400	16	1	1/1
3	502	401	16	1	1/1
4	468	362	16	2	1/1
5	468	325	16	2	1/1
6	1116	77	38	1	1/1
7	419	463	16	1	1/1
8	419	410	16	2	1/1
9	330	386	4	1	1/1
10	1534	478	3	1	1/1

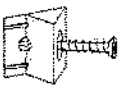



B1  ø8x35 x20	I7  x15	K1  x20	K10  x20	D4  x6
C6  x6	G36  4x30 x4	G34  3,5x16 x13	G49  4x16 x16	F13  x5
I1  x7	M11  x1	G50  3x20 x12	P10  x4	F20  x6

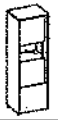

I

K10



x16

B1



ø8x35

x4

K1



x4

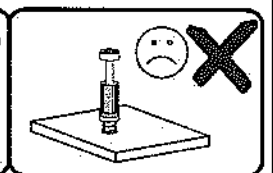
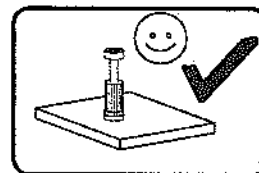
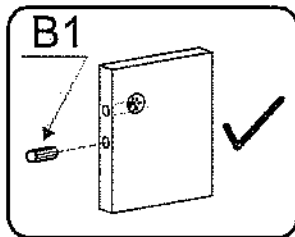
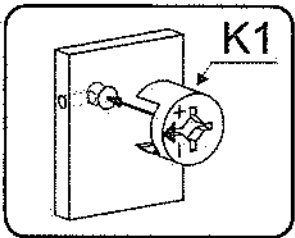
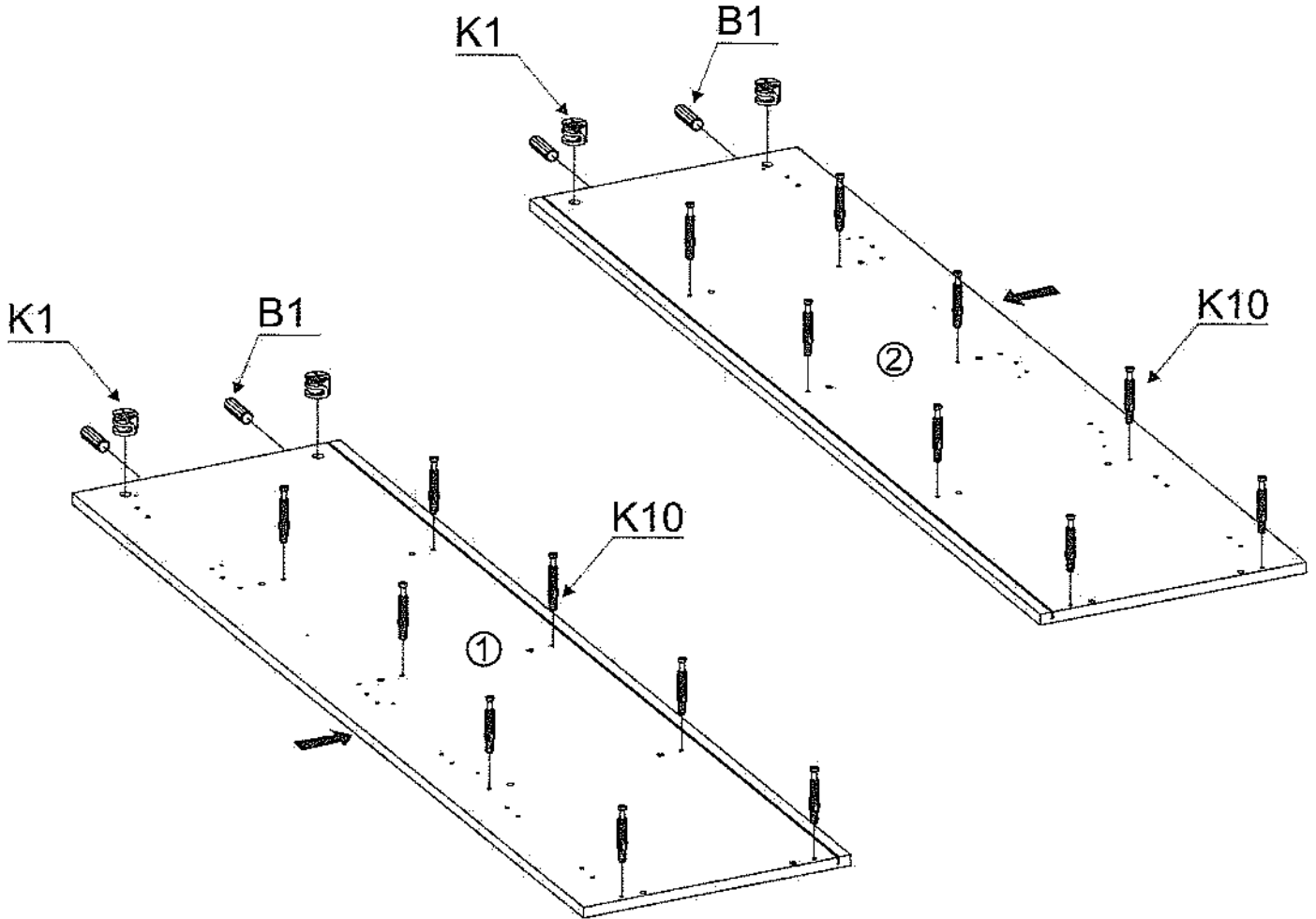

II

K10

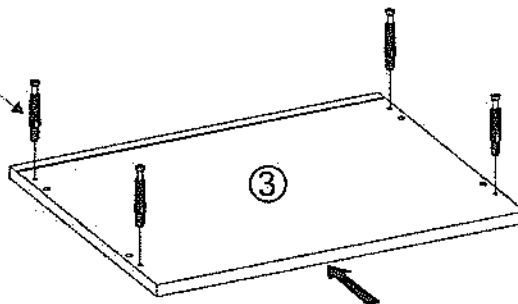

K10



x4



III

B1  x16
 ø8x35

K1  x16

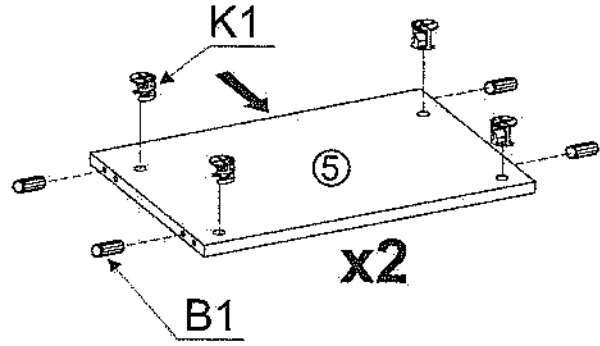
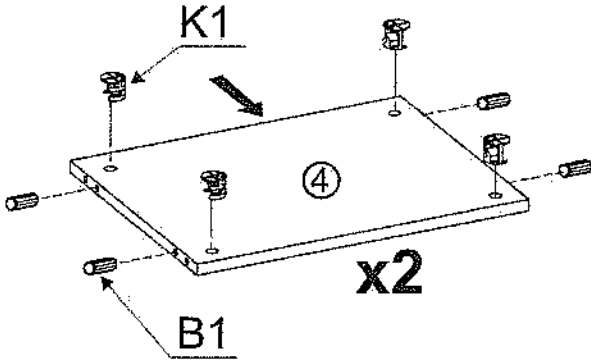

IV

F13  x5

G49  x5
 4x16

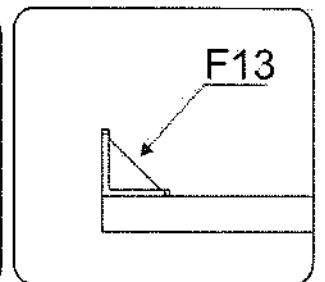
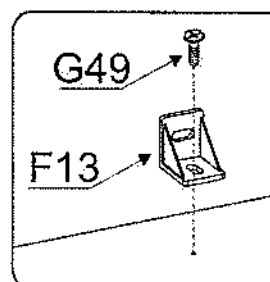
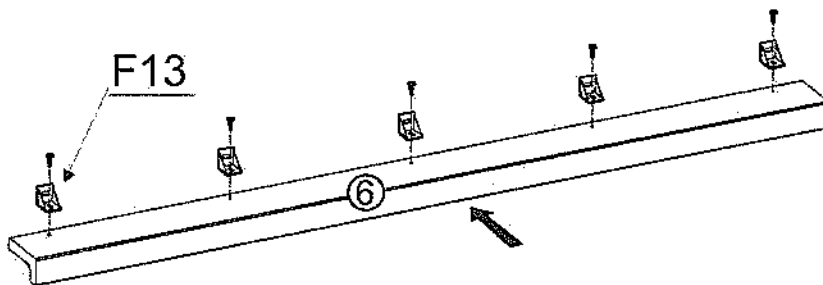



V

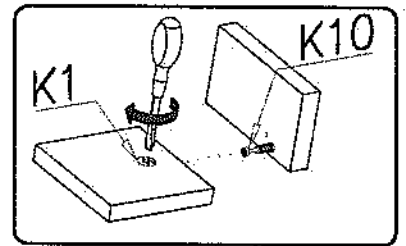
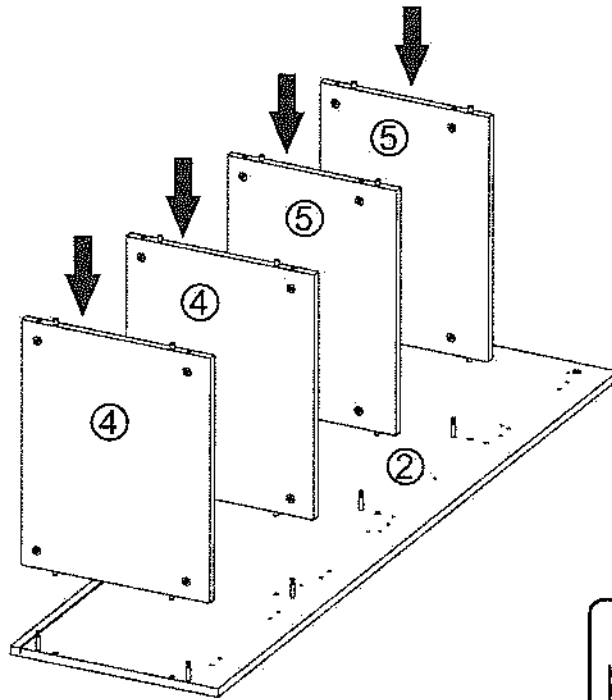
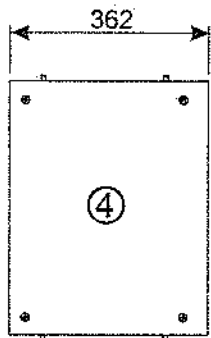
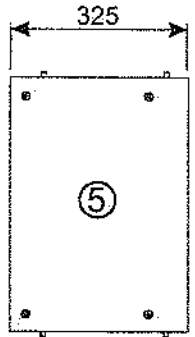

VI

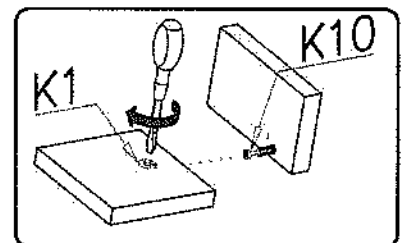
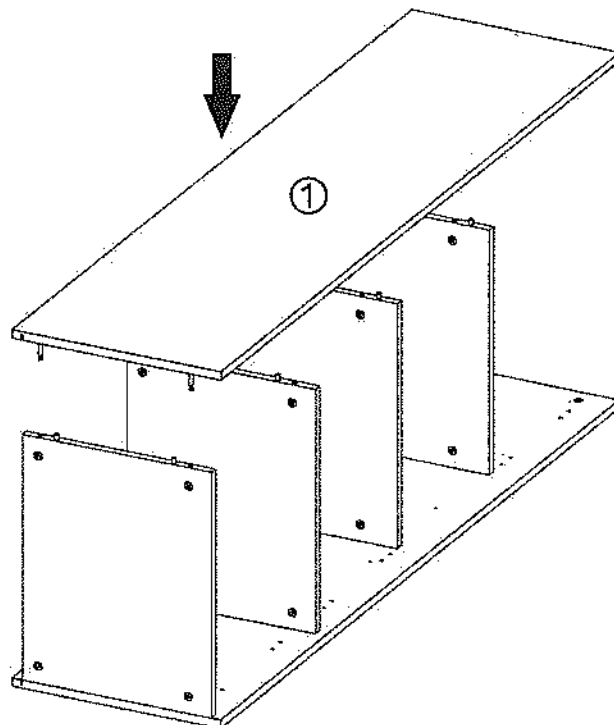



VII

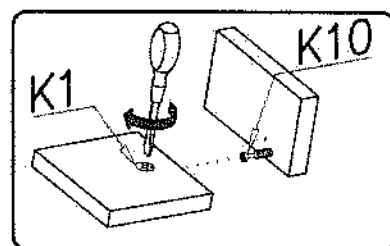
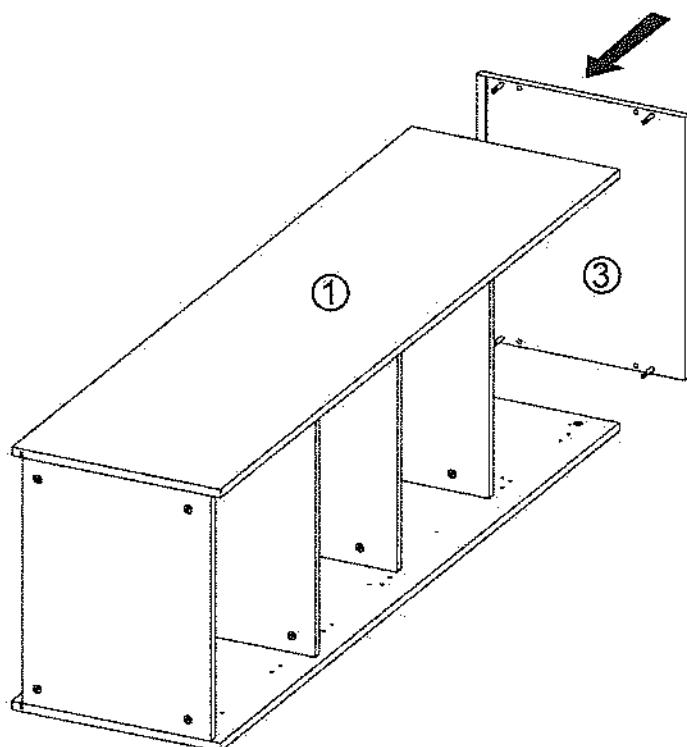

VIII

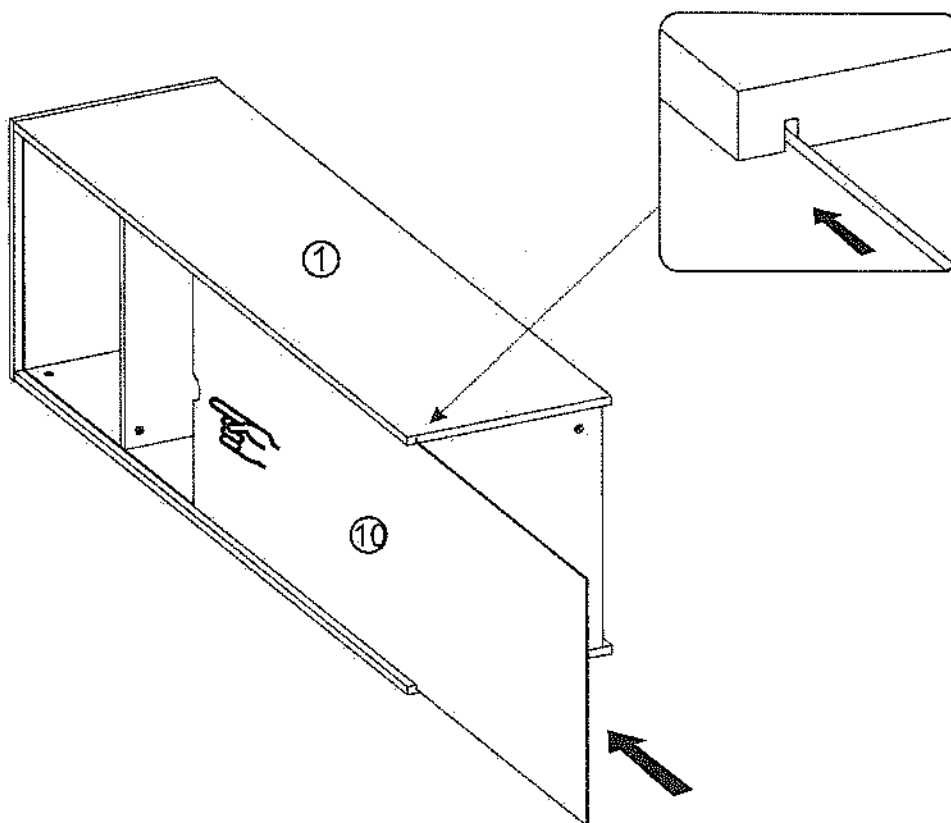

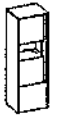

IX

G50

3x20



x12

I1

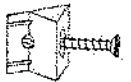

x7

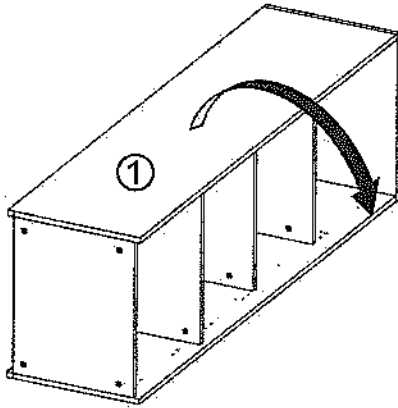

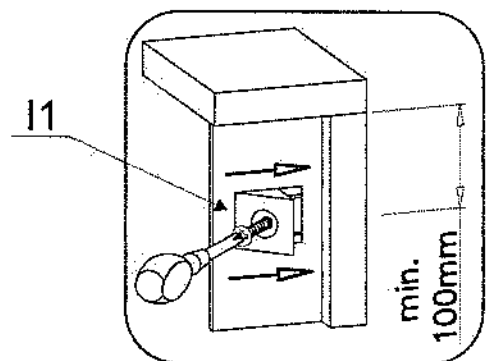
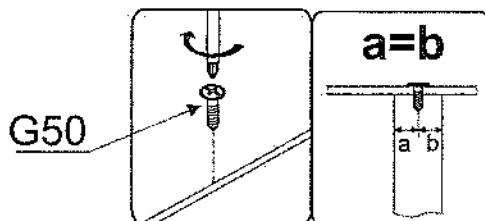
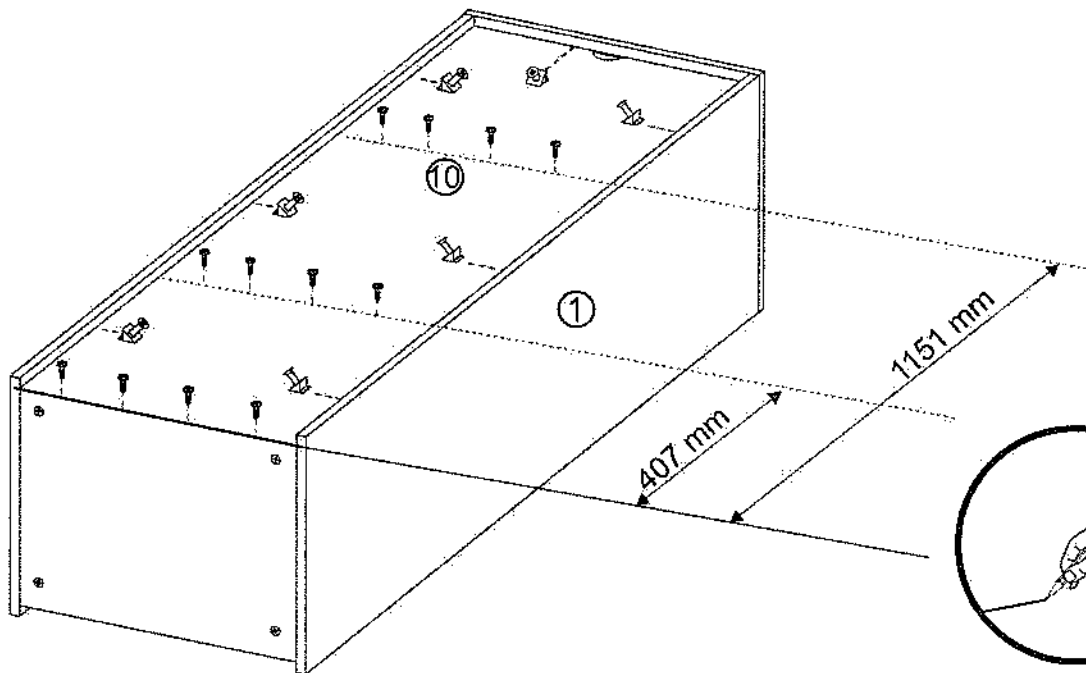
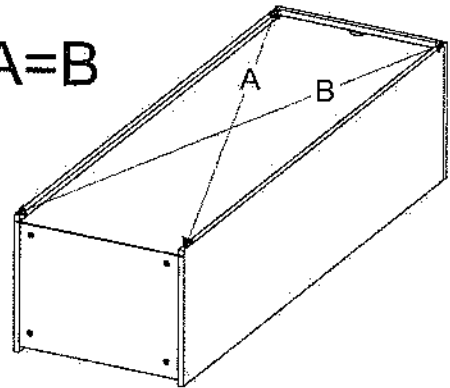

A=B



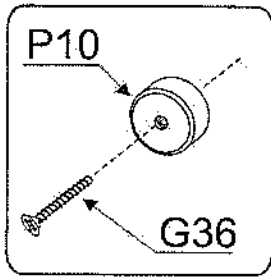

X

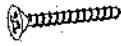

- P10  x4
- G36  4x30 x4

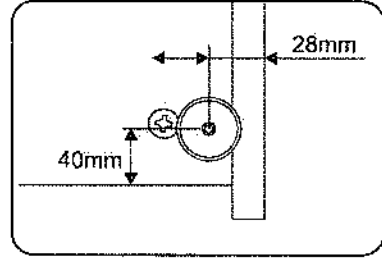
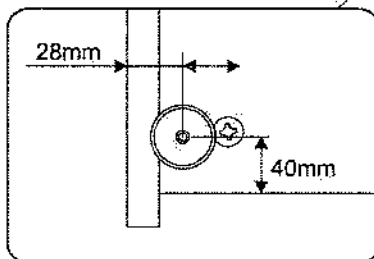
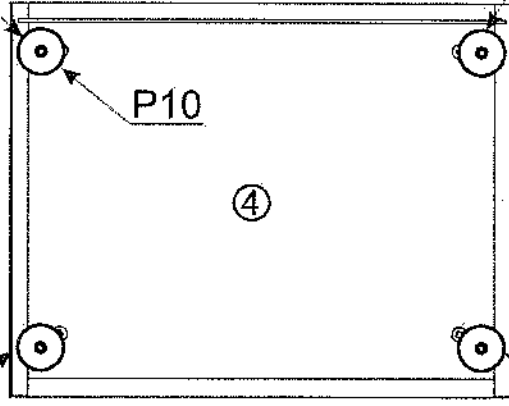
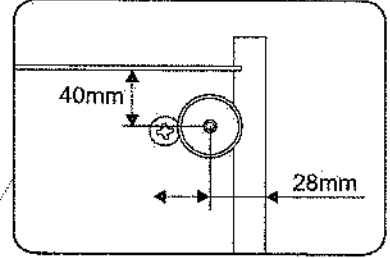
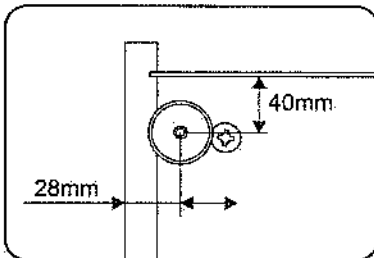
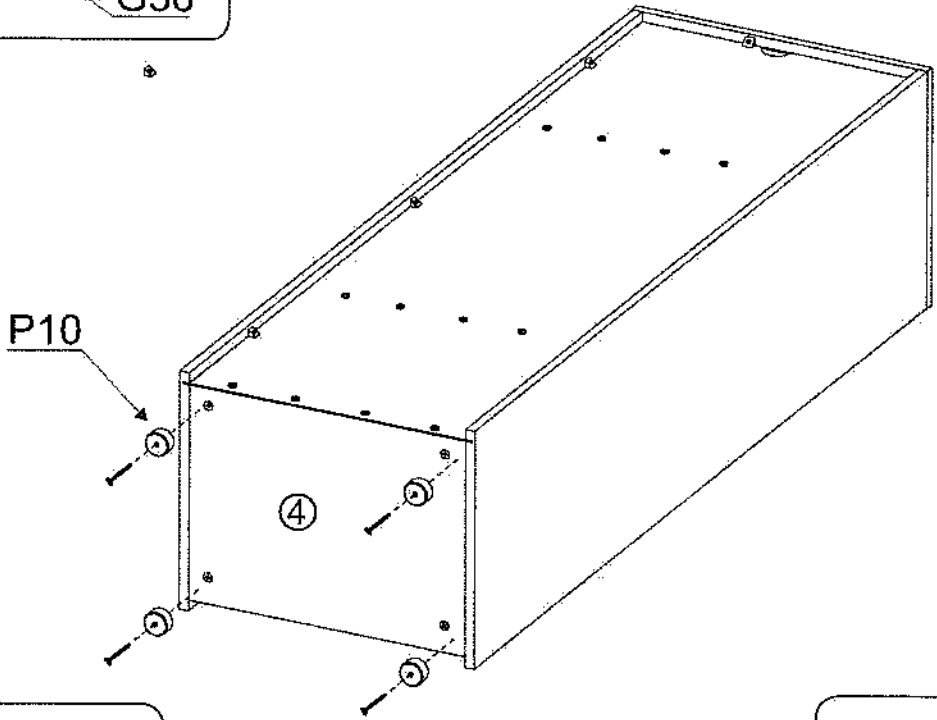



XI

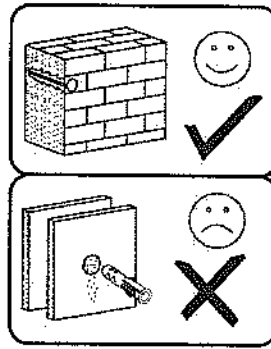
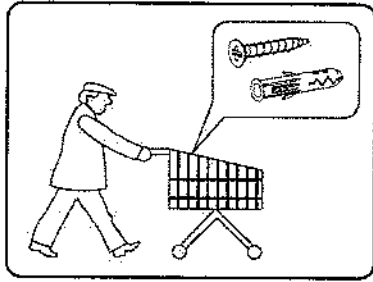

G34		
3,5x16		x1
M11		
		x1

M11

M11

G34

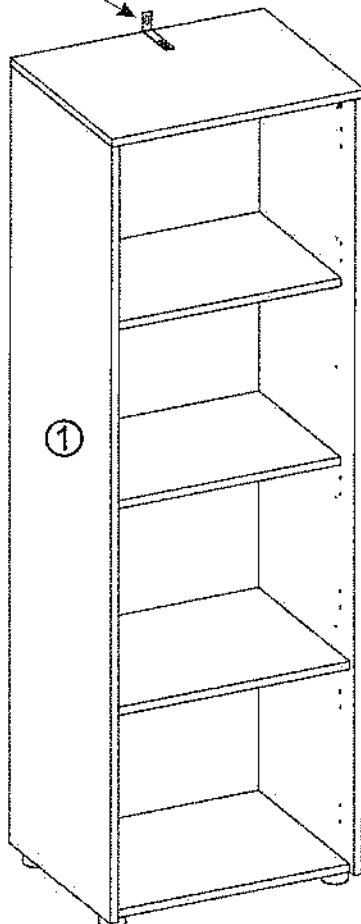
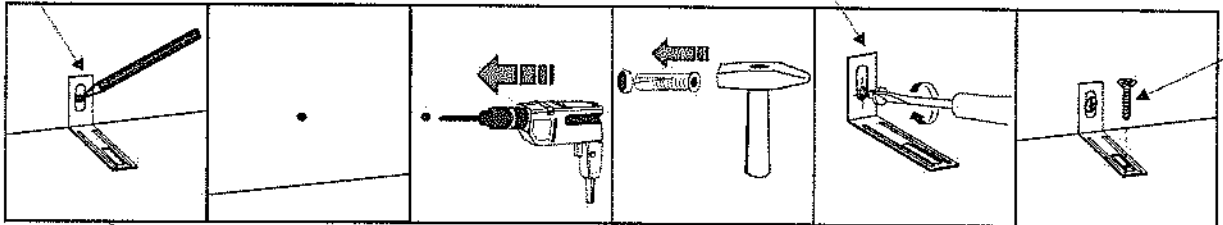



XII

F20



x6

G49



4x16

x6

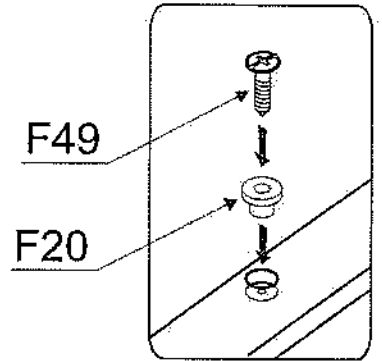
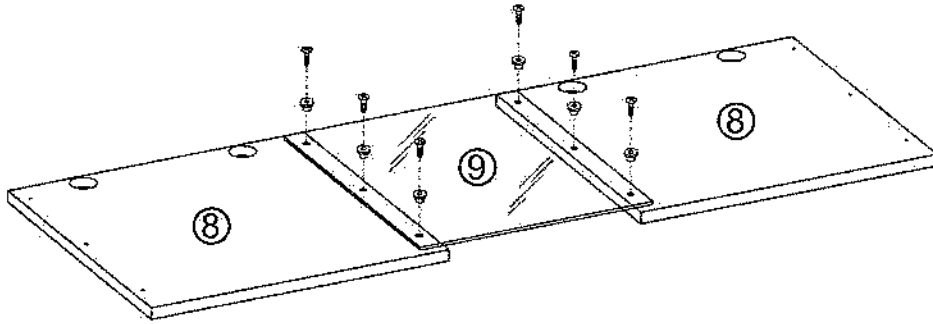

XIII

C6

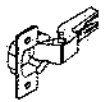

x6

G34



3,5x16

x12

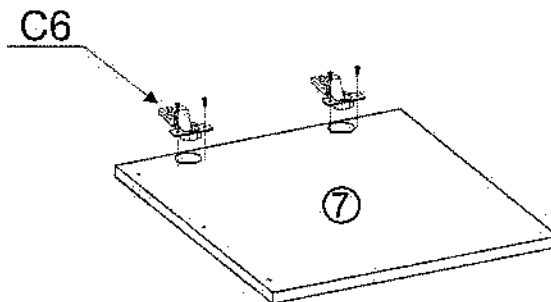
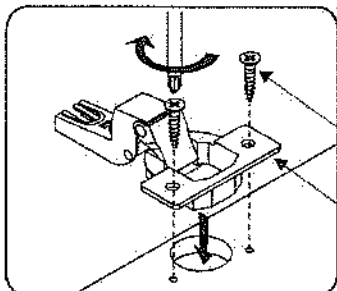
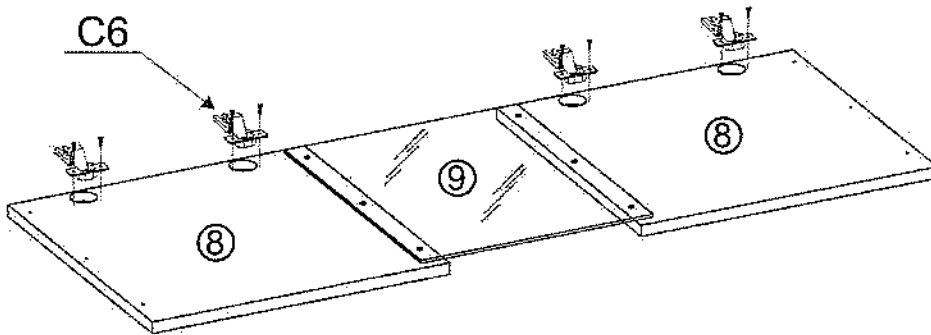



XIV

G49

4x16



x5

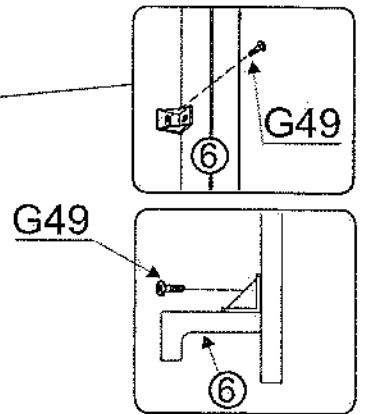
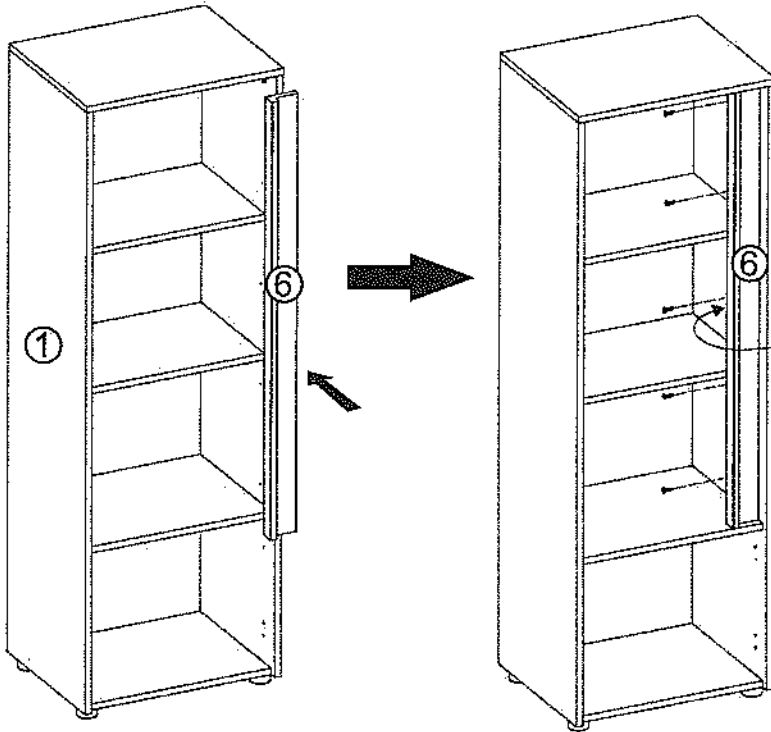
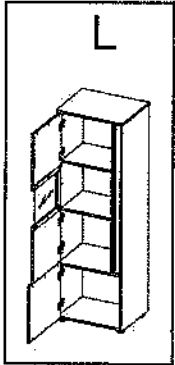

R

G49

4x16



x5

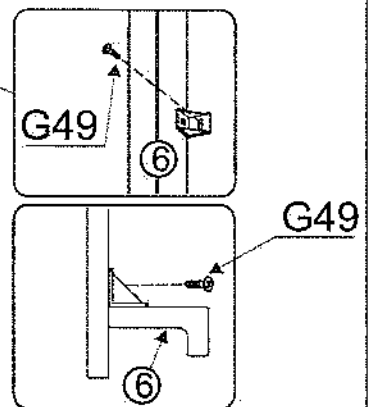
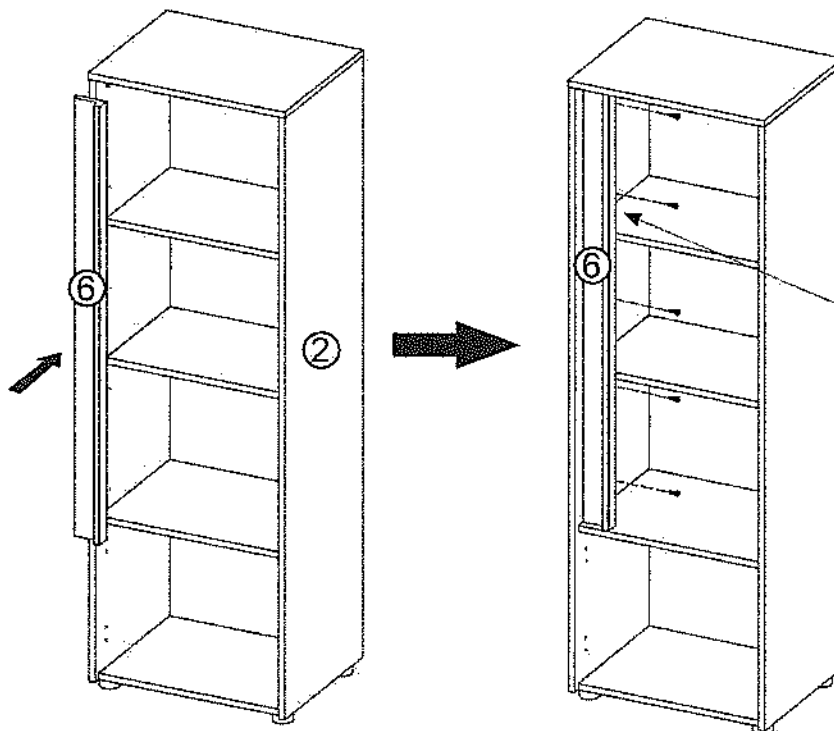
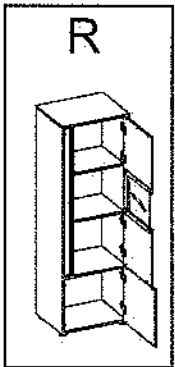



XV

D4



x6

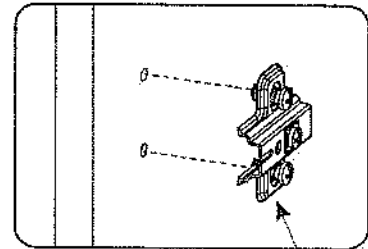
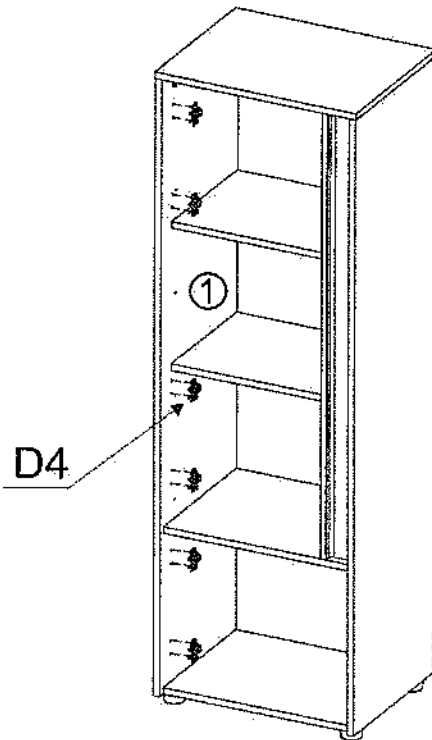
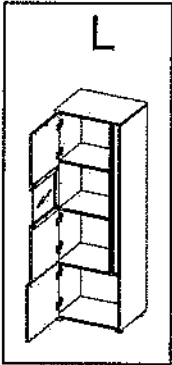

D4

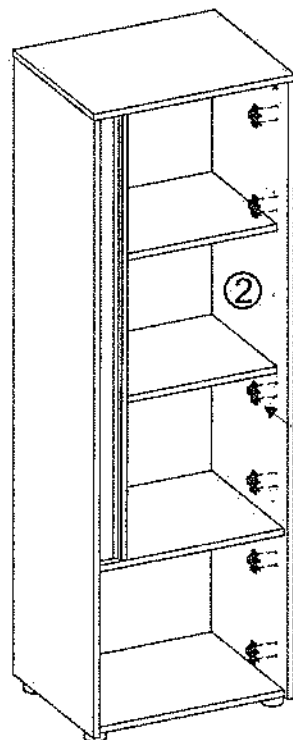
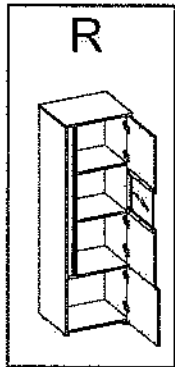

D4



x6

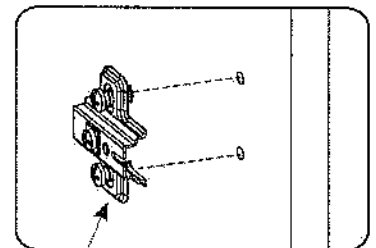

D4

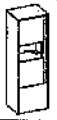

XVI

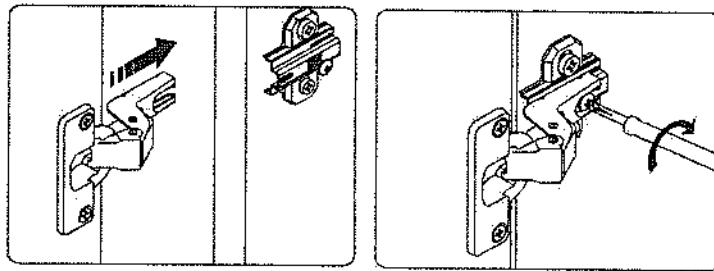
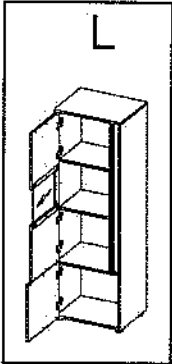

17



x15

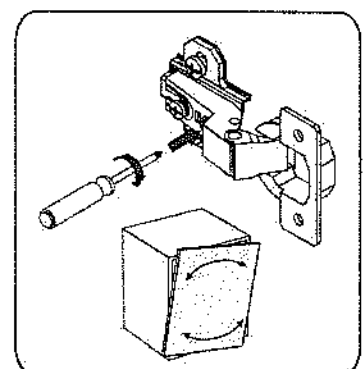
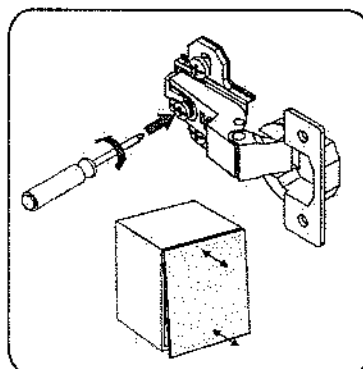
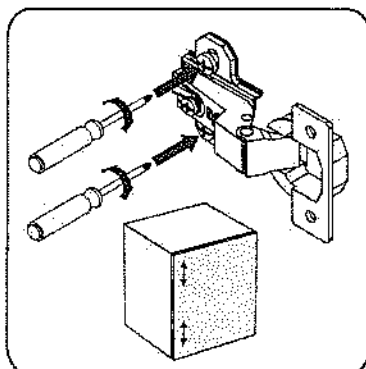
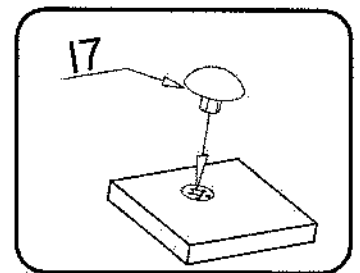
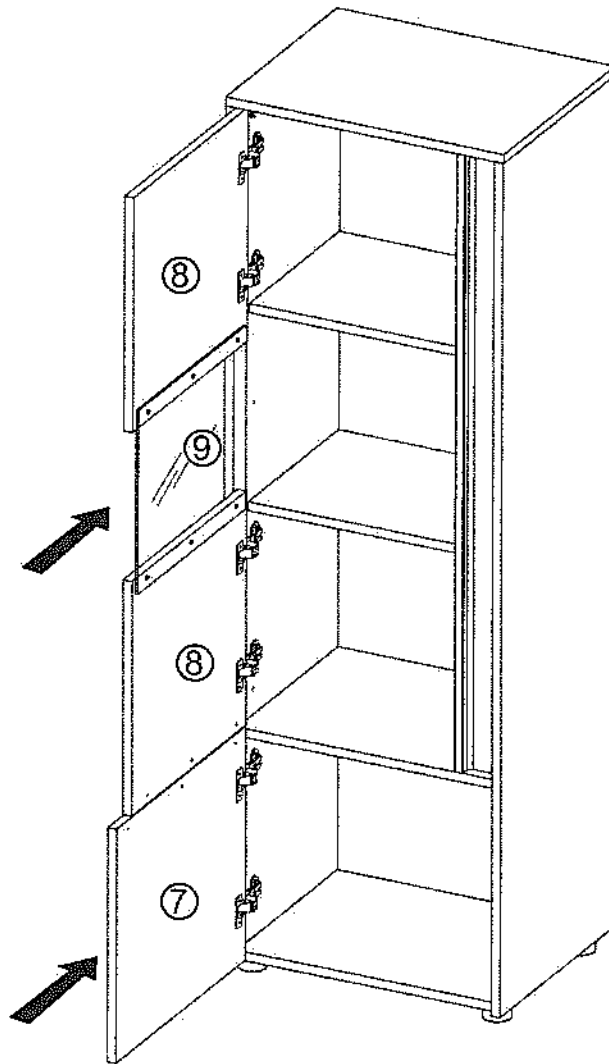

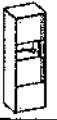

17



x15

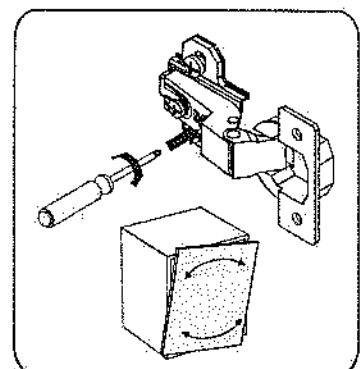
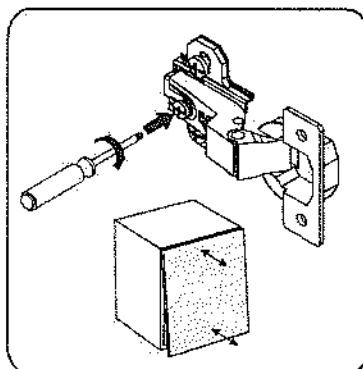
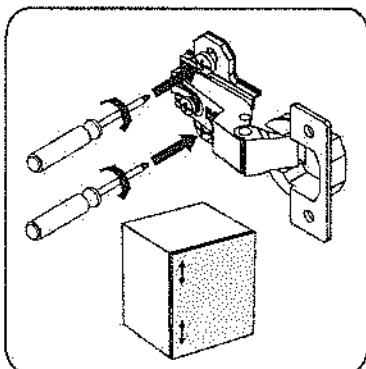
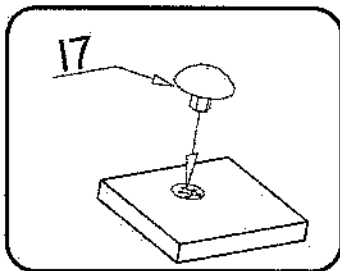
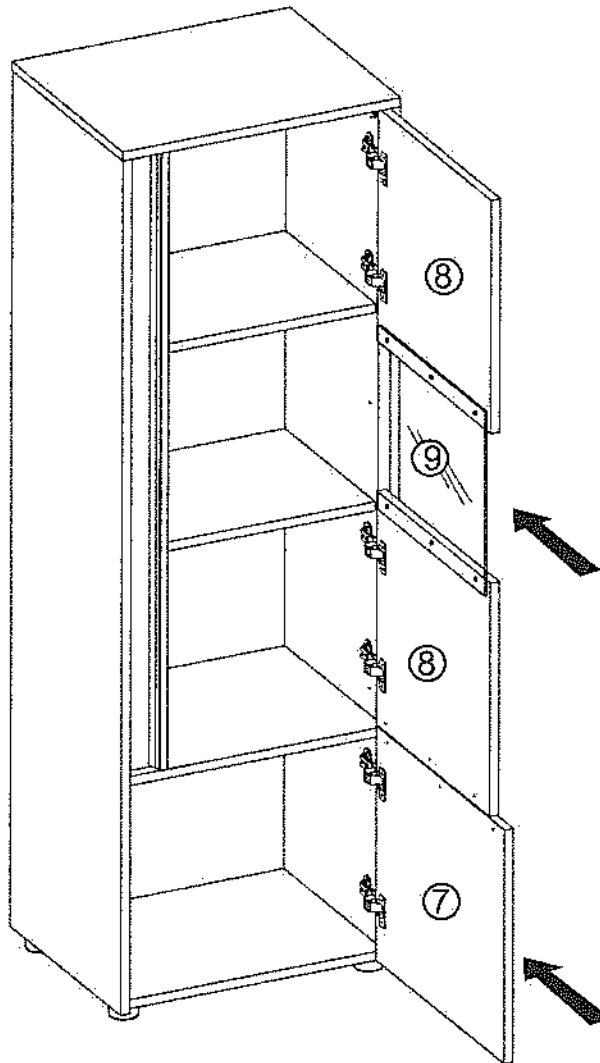
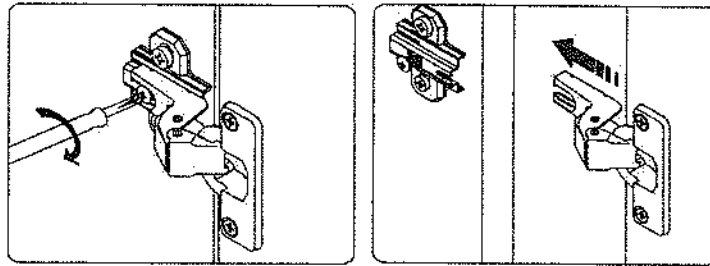
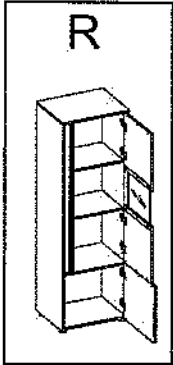

Name • Nom • Nome • Naam • Nazwa • Jméno • Názov • Név • Denumire • Isim • Имя

Nr • No • N° • Номер • Č • Sz

Typ • Type • Tip • Típus • Tipo • Tun

CITY / GIRON

— —

27

D Unser Directservice für Beschädigte
Sollte Ihnen ein Beschädigteil fehlen, können Sie diese Servicekarte direkt an die untenstehende Adresse mailen. Wir können allerdings nur Beschädigte auf diesem Wege verschicken. Sollten Sie eine andere Beanstandung an Ihrem Möbelstück haben, so wenden Sie sich bitte direkt an Ihr Möbelhaus.

GB Our direct order service for fitting
If a fitting part is missing, you can e-mail this service card directly to the address below. However, we can only send fitting parts in this way. If you have any other cause for complaint concerning your item of furniture, please contact your furniture store directly.

CZ Naše online služby pro kování
Chybí-li vám nějaký díl z kování, můžete tuto servisní kartu odeslat e-mailem přímo na níže uvedenou adresu. Touto cestou však můžeme zaslát jen díly kování. Pokud byste reklamovali jiný díl nábytku, obraťte se přímo na svého prodejce nábytku.

F Bien choisir la notice de montage
S'il vous manque une ferrure, veuillez envoyer directement la présente carte service à l'adresse e-mail indiquée ci-dessous. Cependant, ce nous permet uniquement d'envoyer des ferrures. Pour tout autre type de réclamation concernant votre meuble, veuillez contacter directement votre magasin d'ameublement.

I Il nostro servizio diretto per l'ordine della ferramenta
Qualora Vi dovesse mancare un pezzo di fissaggio, allora Vi preghiamo di inviare questa carta di servizio immediatamente all'indirizzo sottostante. Possiamo inviare i pezzi di fissaggio solamente per mezzo di questo procedimento. Qualora doveste avere qualche altra reclamazione in merito al mobile, allora Vi preghiamo di rivolgerVi direttamente al Vostro Negozio di mobili.

BG Нашата директна услуга за обков
Ако липсват части от комплекта, попълнете настоящата сервисна карта и ни я изпратете на e-mail адреса, посочен по-долу. По този начин можем да доставим само монтажни елементи от обкова. Ако установите други дефекти по мебелите, Ви съветваме да се обърнете към мебелната къща/магазин, от който сте закупили стоката.

NL Onze directservice voor losse onderdelen
Wanneer er een onderdeel ontbreekt, kunt u deze servicekaart direct aan onderstaand e-mailadres sturen. Wij kunnen langszes door weg echter alleen beslagdelen versturen. Mocht u een ander probleem aan uw meubel hebben, verzeken wij u contact op te nemen met uw meubeldealer.

PL Nasz bezpośredni serwis części montażowych
Jeżeli brakuje części koniecznych do montażu, prosimy o przesłanie nam niniejszej karty serwisowej na niżej podany adres e-mailowy. W ten sposób możemy przesyłać Państwu tylko brakujące części. W przypadku innych reklamacji dotyczących mebla, prosimy zgłosić się do salonu meblowego, w którym został dokonany zakup.

HR Servis za okova
U slučaju da nedostaje neki od dijelova molimo vas da na dolje navedenu mail adresu pošaljete ovaj servisni obrazac. Na ovaj način mogu se dostaviti samo okovi. U slučaju da imate dodatno prigovora vezane uz komad namještaja molimo vas da se obratite izravno trgovini namještaja gdje je isti kupljen.

HU Direktszoállításunk vasalatók esetén
Ha hiányzik egy vasalat, ezt a kártyát közvetlenül elküldheti az alább található címre. Azonban csak a vasalatókat tudunk így küldeni. Amennyiben másféle reklamáció áll fenn bútorárbáját illetően, forduljon közvetlenül a bútorházaához.

SK Naše priamy servis pro časti kování
Ak by Vám chýbala nejaká časť kování, môžete poslať túto servisnú kartu poslať e-mailom na nižšie uvedenú adresu. Diely kování vieme poslať iba týmto spôsobom. Ak by ste mali inú reklamáciu ohľadom Vášho nábytku, obráťte sa priamo na Vašu predajňu nábytku.

SLO Naša direktno uslužna storitev za okovje
Če vam manjka kakšno okovje, lahko to servisno kartico pošljete po e-pošti direktno na spodnji naslov. Po tej poti vam lahko pošljemo samo okovje. Če želite reklamirati kakšen drug del pohištva, se obrnite neposredno na vašo trgovino pohištva.

RO Service-ul nostru direct pentru feronerie
In cazul in care va lipseste o piesa de feronerie puteti sa trimiteți direct acest card de service prin e-mail la adresa de mai jos. Noi nu putem expedia piese de feronerie decât pe această cale. Dacă aveți o altă reclamație referitoare la piesa de mobilier, atunci vă rugăm să vă adresați direct la magazinul dvs. de mobilă.









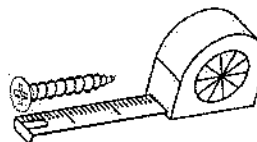



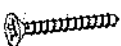

RUS Наш прямой сервис для поставок фурнитуры
Если окажется, что Вам не хватает того или иного элемента фурнитуры, Вы можете отправить сервисную карту по факсу непосредственно на нижеприведенный адрес электронной почты. Однако, таким образом мы можем пересылать лишь фурнитуру. Если же у Вас возникнут иные претензии относительно приобретенной мебели, пожалуйста, обращайтесь непосредственно в организацию, осуществившую продажу.

S Vår direktservice för beslagsdelar
Om du saknar en beslagsdel kan du skicka detta servicekort direkt till e-postadressen som anges nedan. Tänk på att detta är den enda möjligheten att skicka beslagsdelar till dig. Om du vill reklamera din möbel av en annan anledning måste du kontakta ditt möbelhus direkt.

ES Nuestro servicio directo para accesorios
Si lo falta algún accesorio, puede enviar esta tarjeta de servicio directamente a la siguiente dirección. No obstante, por este método sólo podemos enviar accesorios. Si tiene alguna otra objeción sobre su mueble, consulte directamente con su mueblería.

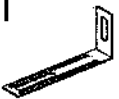
TR Donatilan için doğrudan servisimiz
Bir donatıya eksiklik bu servis kartını doğrudan aşağıda bulunan adrese doğrudan mail yazabilirsiniz. Sadece bu yolla donatılan gönderabiliriz. Mobilyanızda başka şikayetleriniz varsa lütfen doğrudan mobilya satışçınıza danışın.



B1 Ø8x35 X... 	I7 X... 	K1 X... 
K10 X... 	D4 X... 	C6 X... 
G36 4x30 X... 	G34 3,5x16 X... 	G49 4x16 X... 
F13 X... 	I1 X... 	M11 X... 
G50 3x20 X... 	P10 X... 	F20 X... 

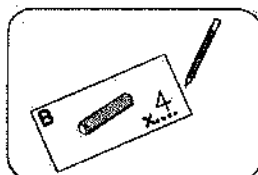

Name • Nom • Nome • Naam • Nazwa • Имяно
• Názov • Név • Denumire • Isim • Имявание

Nr • No • N° • Номер • Č • Sz

Typ • Type • Tip • Típus • Tipo • Тип

CITY / GIRON

— —

27

D Unser Direktservice für Beschlagteile
Sollte Ihnen ein Beschlagteil fehlen, können Sie diese Servicekarte direkt an die untenstehende Adresse mailen. Wir können allerdings nur Beschlagteile auf diesem Wege verschicken. Sollten Sie eine andere Beanstandung an Ihrem Möbelstück haben, so wenden Sie sich bitte direkt an Ihr Möbelhaus.

GB Our direct order service for fitting
If a fitting part is missing, you can e-mail this service card directly to the address below. However, we can only send fitting parts in this way. If you have any other cause for complaint concerning your item of furniture, please contact your furniture store directly.

CZ Naše přímé služby pro kování
Chybí-li vám nějaký díl z kování, můžete tuto servisní kartu odeslat e-mailem přímo na níže uvedenou adresu. Touto cestou však můžeme rozesílat jen díly kování. Pokud byste reklamovali jiný díl nábytku, obraťte se přímo na svého prodejce nábytku.

F Bien atudier la notice de montage
Si'il vous manque une ferrure, veuillez envoyer directement la présente carte service à l'adresse e-mail indiquée ci-dessous. Cependant, ceci nous permet uniquement d'envoyer des ferrures. Pour tout autre type de réclamation concernant votre meuble, veuillez contacter directement votre magasin d'ameublement.

I Il nostro servizio diretto per l'ordine della ferramenta
Qualora Vi dovesse mancare un pezzo di fissaggio, allora Vi preghiamo di inviare questa carta di servizio immediatamente all'indirizzo sottostante. Possiamo inviare i pezzi di fissaggio solamente per mezzo di questo procedimento. Qualora dovete avere qualche altra reclamazione in merito al mobile, allora Vi preghiamo di rivolgerVi direttamente al Vostro Negoziolo di mobili.

BG Нашата директна услуга за обкова
Ако липсват части от комплекта, попълнете настоящата сервисна карта и ни я изпратете на e-mail адреса, посочен по-долу. По този начин можем да доставяме само липсващи елементи от обкова. Ако установите други дефекти по мебелите, Ви съветваме да се обърнете към мебелната къща/магазин, от който сте закупили стоката.

NL Onze directservice voor losse onderdelen
Wanneer er een onderdeel ontbreekt, kunt u deze servicekaart direct aan onderstaand e-mailadres sturen. Wij kunnen langs deze weg echter alleen beslagdelen verzenden. Mocht u een ander probleem aan uw meubel hebben, verzoeken wij u contact op te nemen met uw meubeldealer.

PL Nasz bezpośredni serwis części montażowych
Jeżeli brakuje części koniecznych do montażu, prosimy o przesłanie nam niniejszej karty serwisowej na niżej podany adres e-mailowy. W ten sposób możemy przesyłać Państwu tylko brakujące części. W przypadku innych reklamacji dotyczących mebla, prosimy zgłosić się do salonu meblowego, w którym został dokonany zakup.

HR Servis za okove
U slučaju da nedostaje neki od dijelova molimo vas da na dole navedenu mail adresu pošaljete ovaj servisni obrazac. Na ovaj način mogu se dostaviti samo okovi. U slučaju da imate dodatne prigovore vezane uz komad namještaja molimo vas da se obratite izravno trgovini namještaja gdje je isti kupljen.

HU Direktszolgáltatunk vasalatok esetén
Ha hiányzik egy vasalat, ezt a kártyát közvetlenül elküldheti az alább található címre. Azonban csak a vasalatokat tudunk így küldeni. Amennyiben másféle reklamációt áll fenn birtokdarabjait illetően, forduljon közvetlenül a boltiáruházhoz.

SK Naš priamy servis pre časti kovania
Ak by Vám chýbala nejaká časť kovania, môžete poslať túto servisnú kartu poslať e-mailom na nižšie uvedenú adresu. Diely kovania vieme poslať iba týmto spôsobom. Ak by ste mali inú reklamáciu ohľadom Vášho nábytku, obráťte sa priamo na Vašu predajňu nábytku.

SLO Naše direktno uslužne storitve za okovje
Če vam manjka kakšno okovje, lahko to servisno kartico pošljete po e-pošti direktno na spodnji naslov. Po tej poti vam lahko pošljemo samo okovje. Če želite reklamirati kakšen drug del pohištva, se obrnite neposredno na vašo trgovino pohištva.

RO Service-ul nostru direct pentru feronerie
In cazul în care vă lipsesc te o piesă de feronerie puteți să trimiteți direct acest card de service prin e-mail la adresa de mai jos. Noi nu putem expedia piesa de feronerie decât pe această cale. Dacă aveți o altă reclamație referitoare la piesa de mobilier, atunci vă rugăm să vă adresați direct la magazinul dvs. de mobilier.

RUS Наш прямой сервис для рекламаций фурнитуры
Если ожидается, что Вам не хватает того или иного элемента фурнитуры, Вы можете отправить сервисную карту по факсу непосредственно на нижеприведенный адрес электронной почты. Однако, таким образом мы можем пересылать лишь фурнитуру. Если же у Вас возникнут иные претензии относительно приобретенной мебели, пожалуйста, обращайтесь непосредственно в организацию, осуществляющую продажу.

S Vår direktservice för beslagsdelar
Om du saknar en beslagsdel kan du skicka detta servicekort direkt till e-postadressen som anges nedan. Tänk på att detta är den enda möjligheten att skicka beslagsdelar till dig. Om du vill reklamera din möbel av en annan anledning måste du kontakta ditt möbelhus direkt.

ES Nuestro servicio directo para accesorios
Si le falta algún accesorio, puede enviar esta tarjeta de servicio directamente a la siguiente dirección. No obstante, por este método solo podemos enviar accesorios. Si tiene alguna otra objeción sobre su mueble, consulte directamente con su mueblería.

TR Donatılar için doğrudan servisimiz
Bir donatınız eksikse bu servis kartını doğrudan aşağıda bulunan adrese doğrudan mail yazabilirsiniz. Sadece bu yolla donatılar gönderiliriz. Mobilyanızda başka şikayetleriniz varsa lütfen doğrudan mobilya satıcınıza danışın.

nr	L[mm]	B[mm]	T[mm]	Menge	Colli
1	1532	400	16	1	1/1
2	1532	400	16	1	1/1
3	502	401	16	1	1/1
4	468	362	16	2	1/1
5	468	325	16	2	1/1
6	1116	77	38	1	1/1
7	419	463	16	1	1/1
8	419	410	16	2	1/1
9	330	386	4	1	1/1
10	1534	478	3	1	1/1

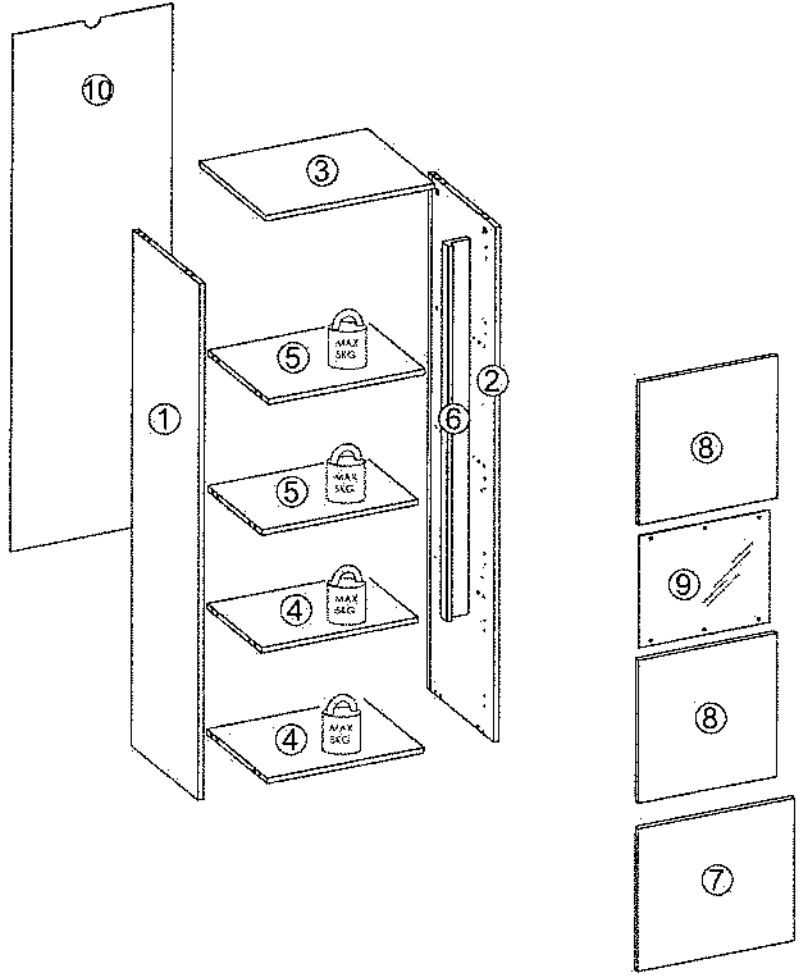

Modell: CITY / GIRON 46

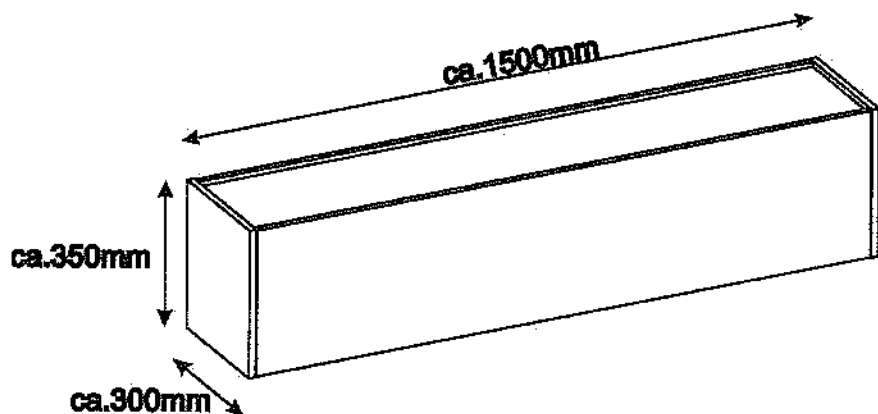

- Ⓓ Montageanleitung
- Ⓐ Handleiding voor de montage
- Ⓓ Montaj talimatı
- Ⓕ Notice de montage
- Ⓒ Montážní návod
- Ⓗ Szerelési útmutató
- Ⓒ Assembly Instructions
- Ⓐ Instrukcja montażu
- Ⓒ Инструкция по монтажу
- Ⓘ Istruzioni di montaggio
- Ⓐ Návod na montáž
- Ⓐ Instrucțiunile de montaj
- Ⓒ Instrucciones de montaje
- Ⓓ Montaj Talimatı

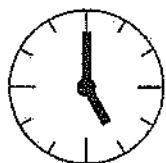
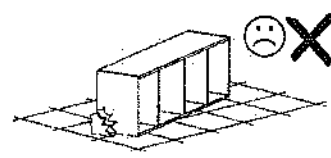
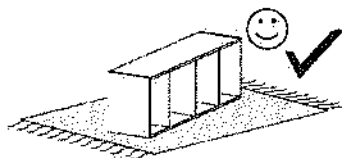
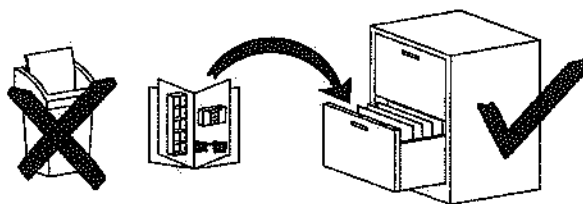
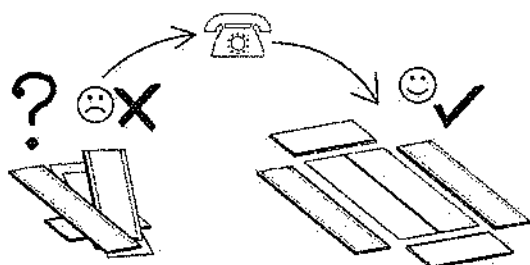
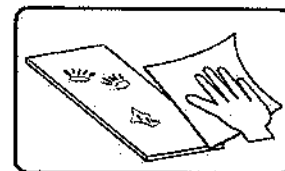
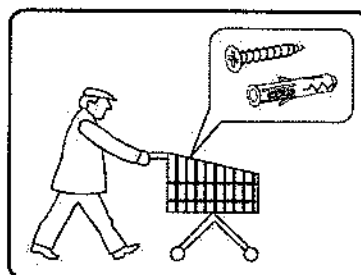
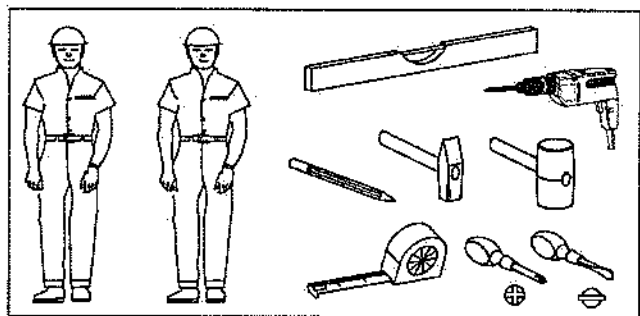

1 h

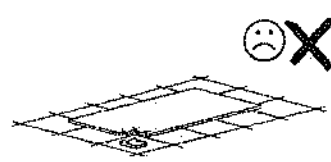
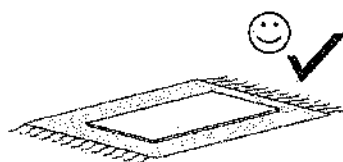

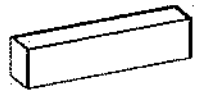



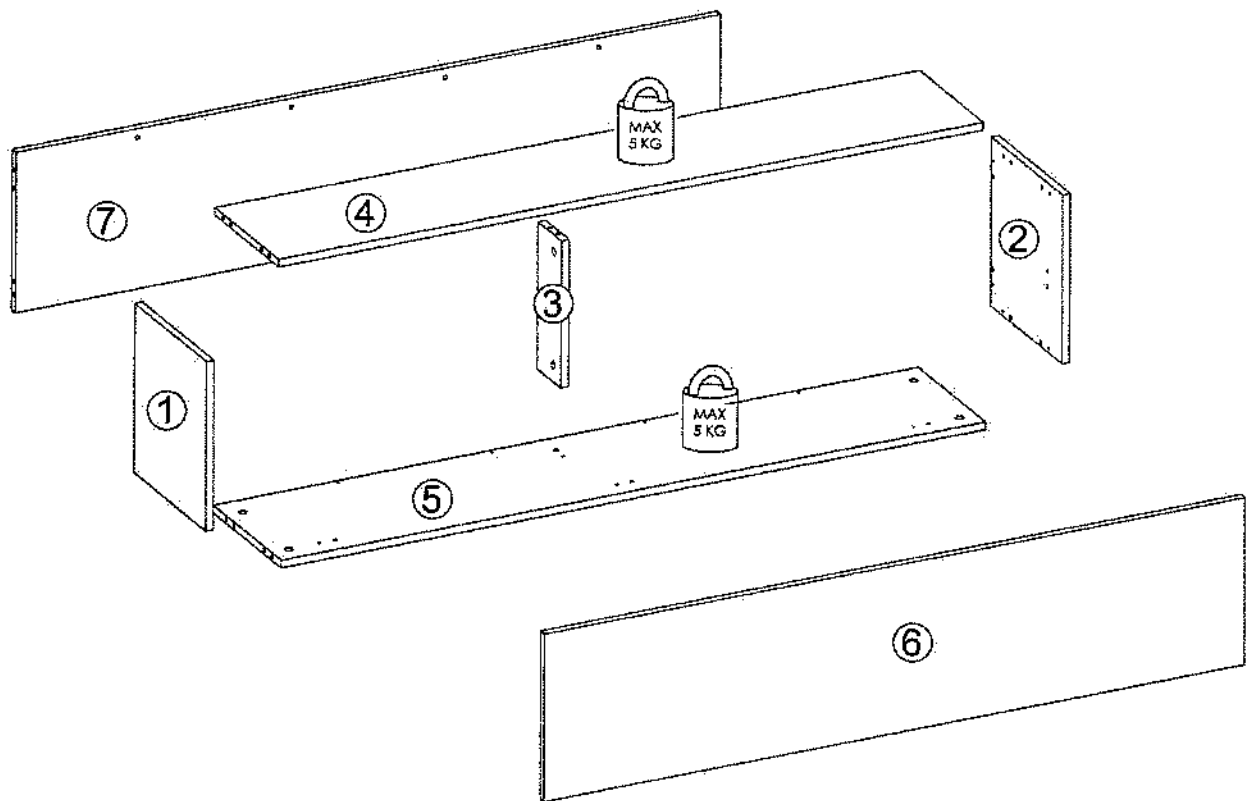

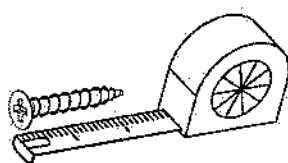
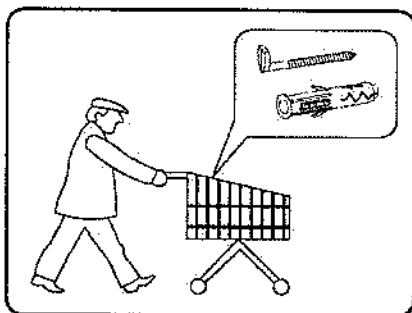
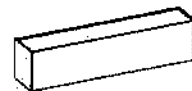



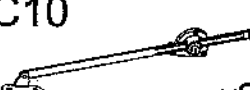

nr	L[mm]	B[mm]	t[mm]	Menge	Coll
1	350	300	16	1	1/1
2	350	300	16	1	1/1
3	305	100	16	1	1/1
4	1468	266	16	1	1/1
5	1468	283	16	1	1/1
6	1463	347	16	1	1/1
7	1468	332	16	1	1/1

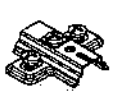
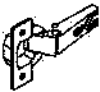



<p>B1</p>  <p>ø8x35 x14</p>	<p>A1</p>  <p>ø7x50 x4</p>	<p>W2</p>  <p>x1</p>	<p>I7</p>  <p>x10</p>	<p>C10</p>  <p>x2</p>
<p>K1</p>  <p>x18</p>	<p>K10</p>  <p>x18</p>	<p>D6</p>  <p>x3</p>	<p>C1</p>  <p>x3</p>	<p>G34</p>  <p>3,5x16 x18</p>
<p>P10</p>  <p>x3</p>	<p>G52</p>  <p>5x11 x6</p>			

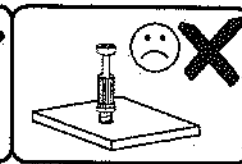
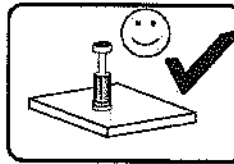
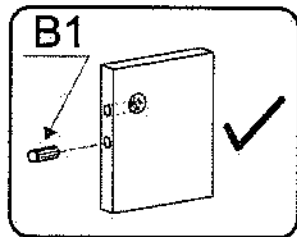
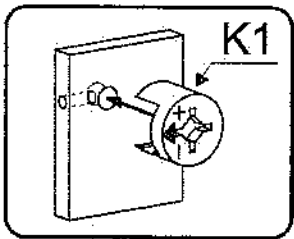
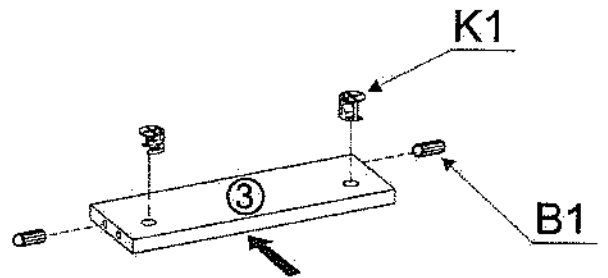
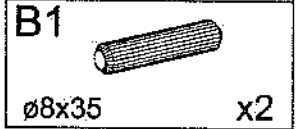
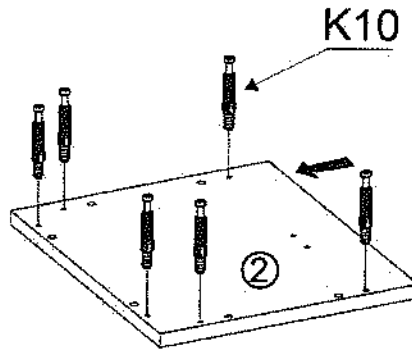
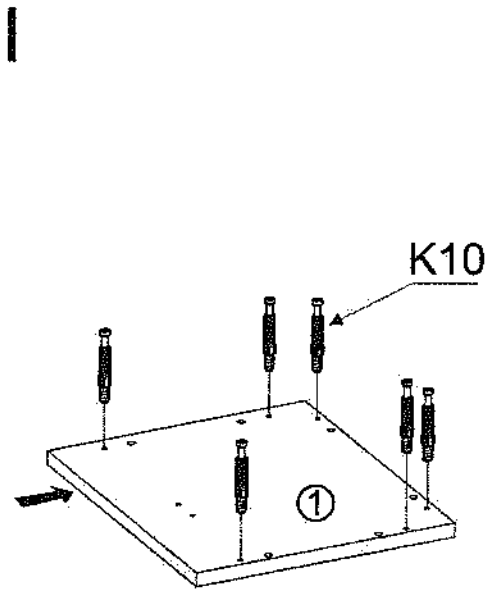
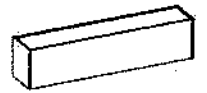

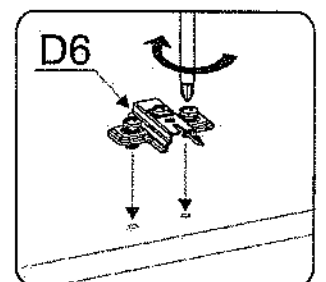
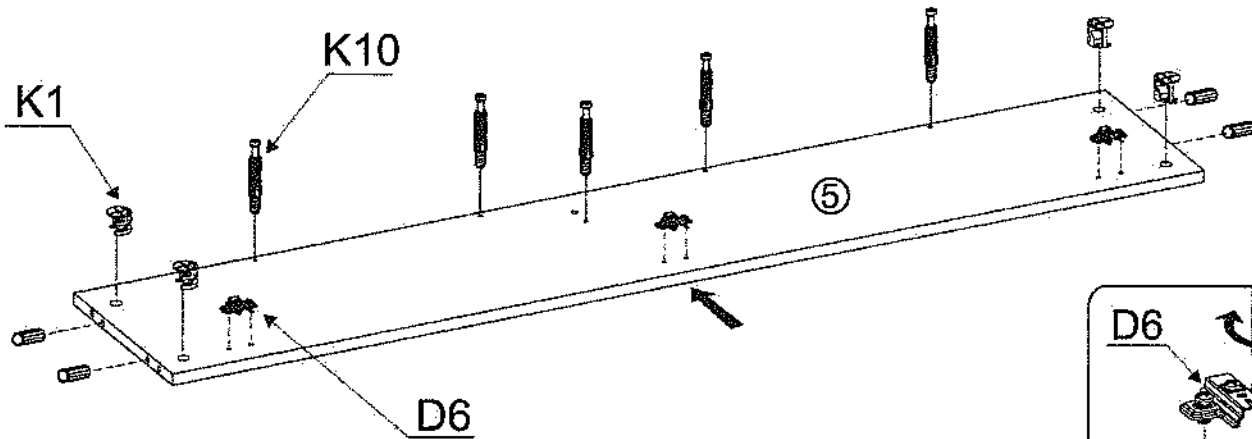
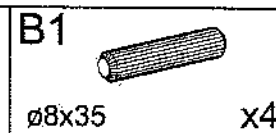

II

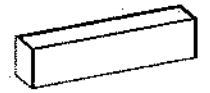





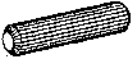

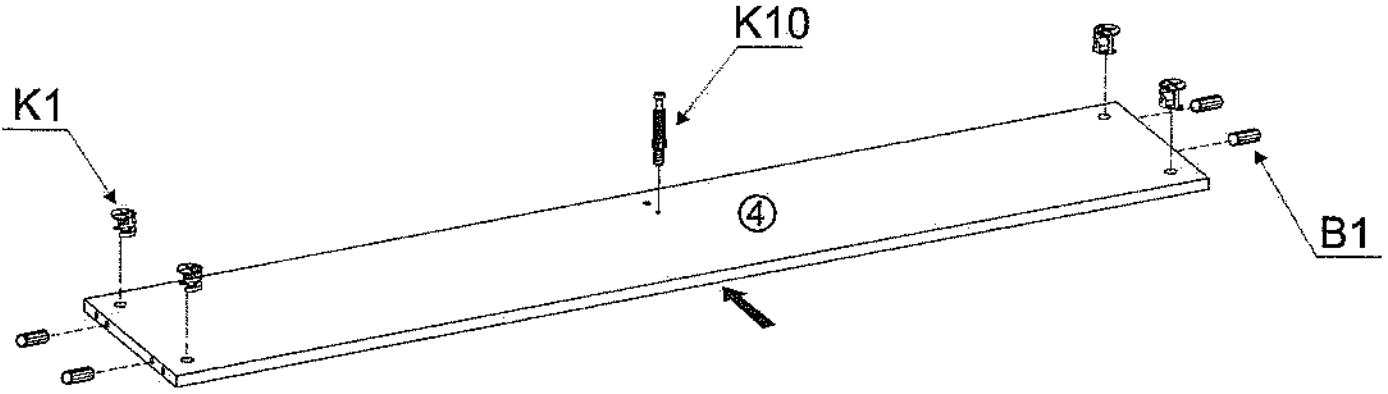
III

K10		x1
K1		x4
B1		x4
ø8x35		



IV

G52		x6
P10		x3
K1		x8
B1		x4
ø8x35		

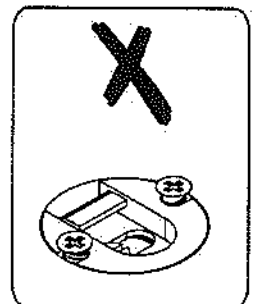
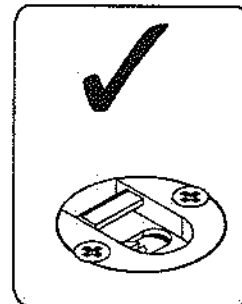
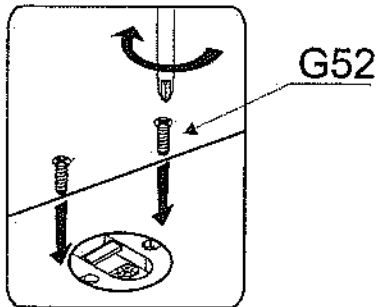
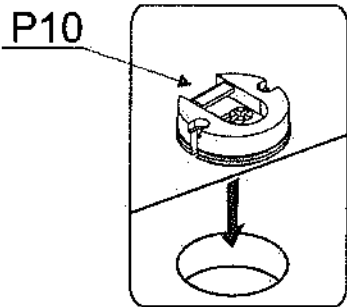
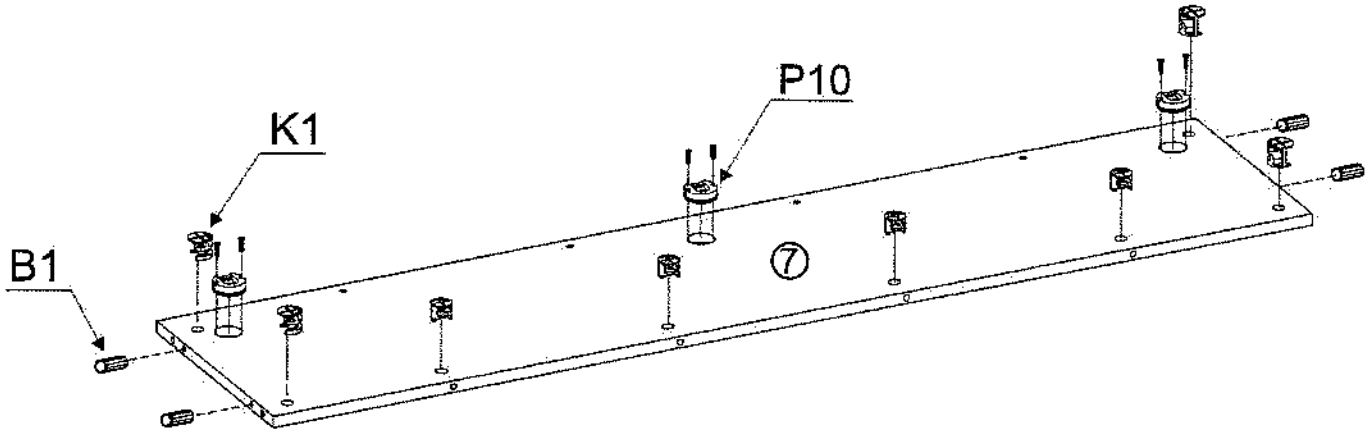

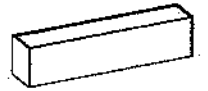

V

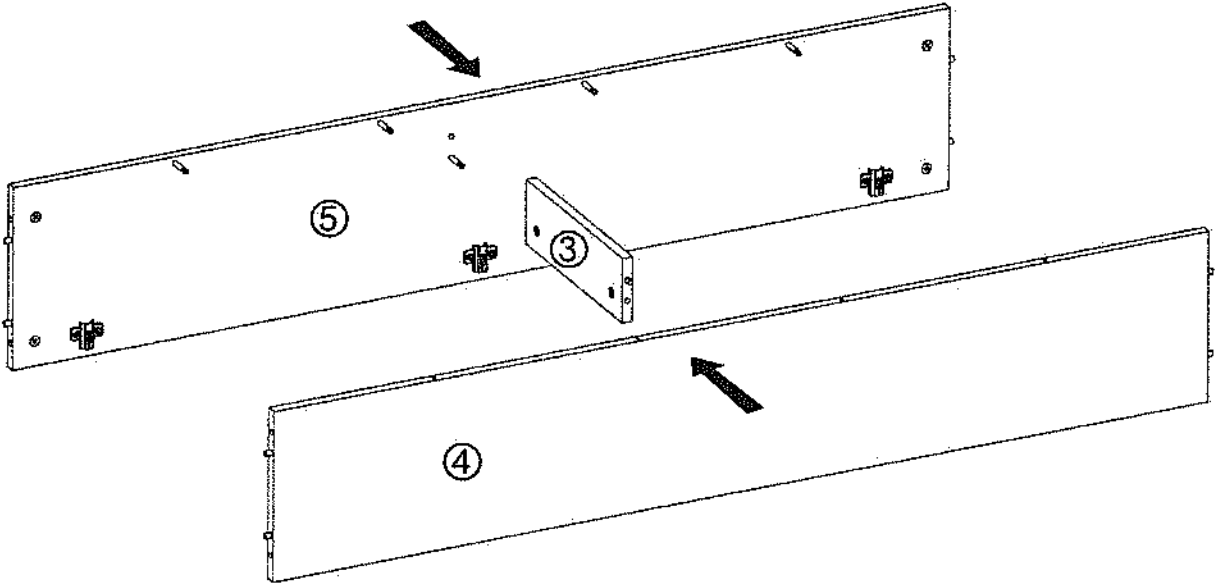
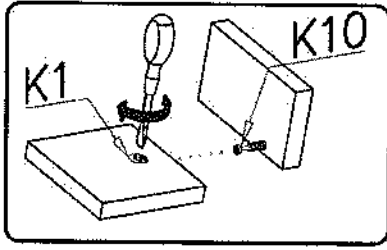

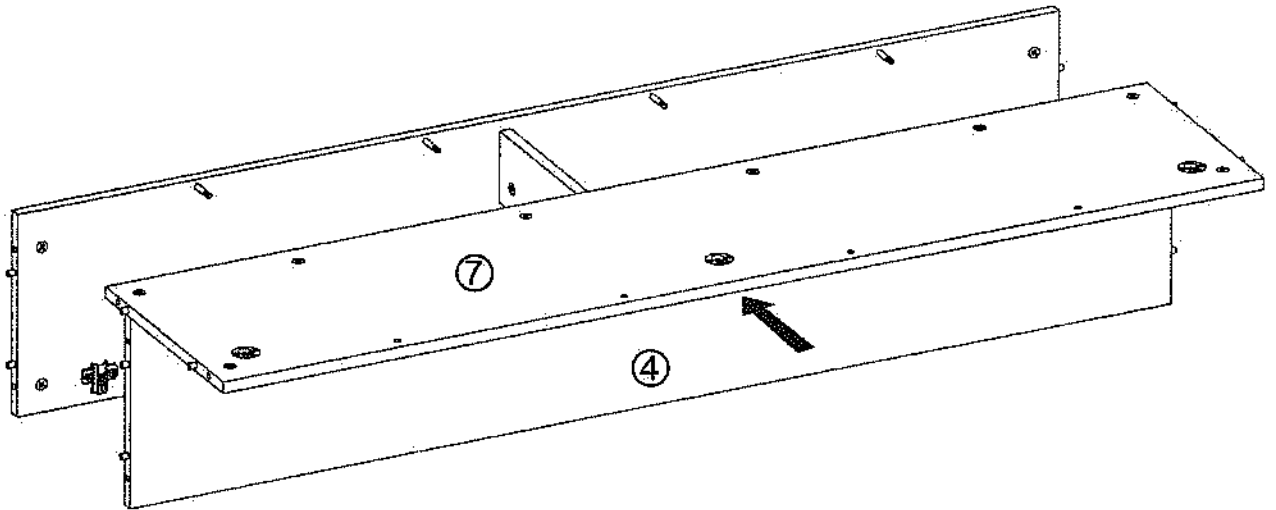
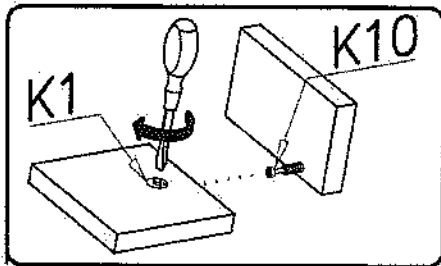

VI

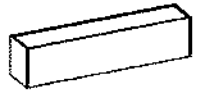

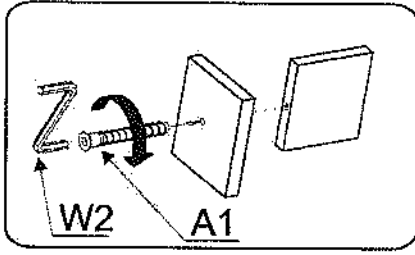

VII

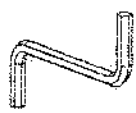

- A1  x4
ø7x50
- W2  x1

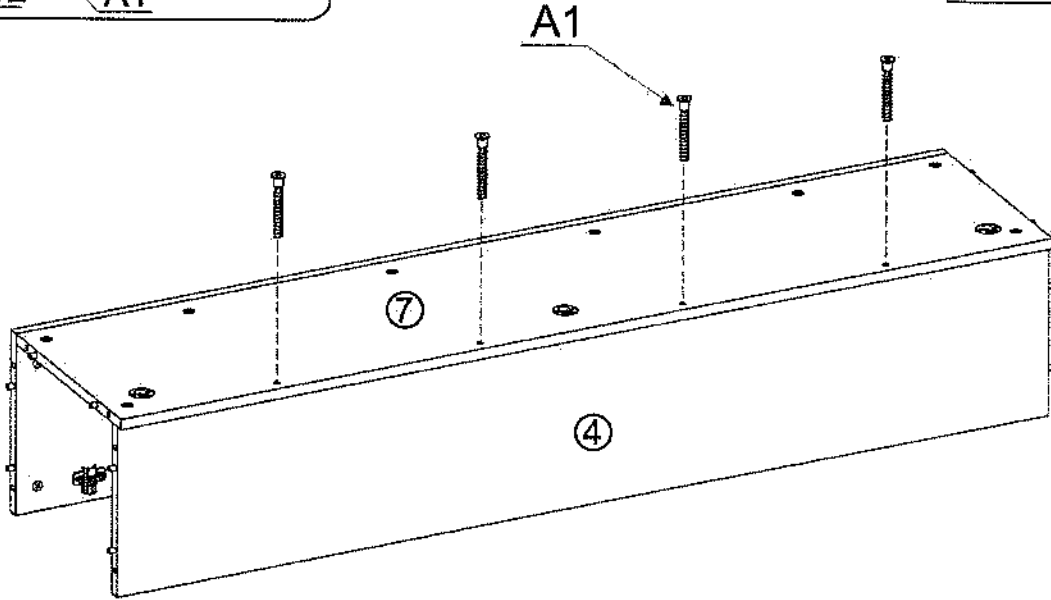

VIII

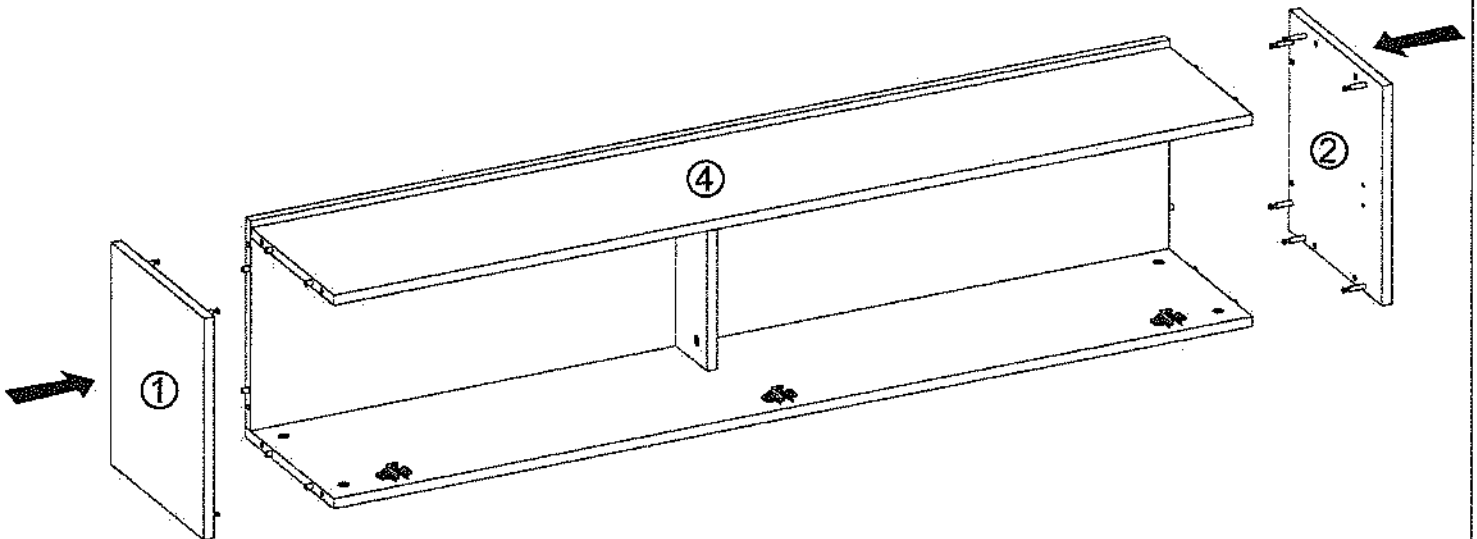
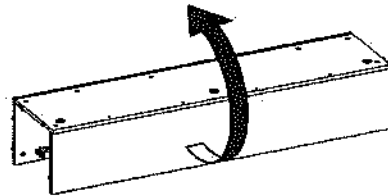
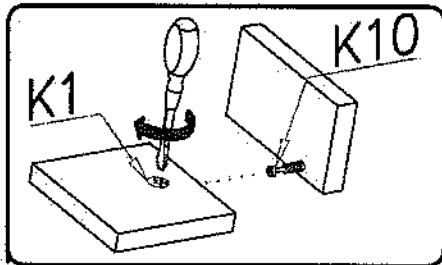

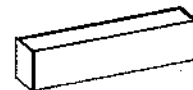

IX

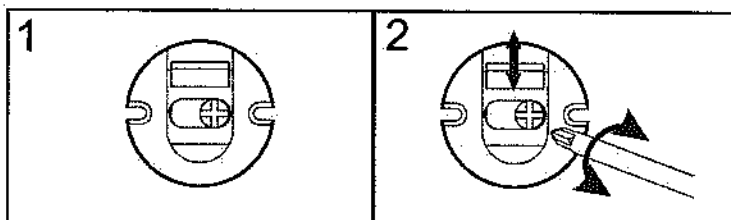
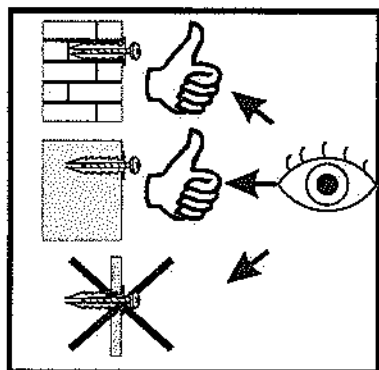
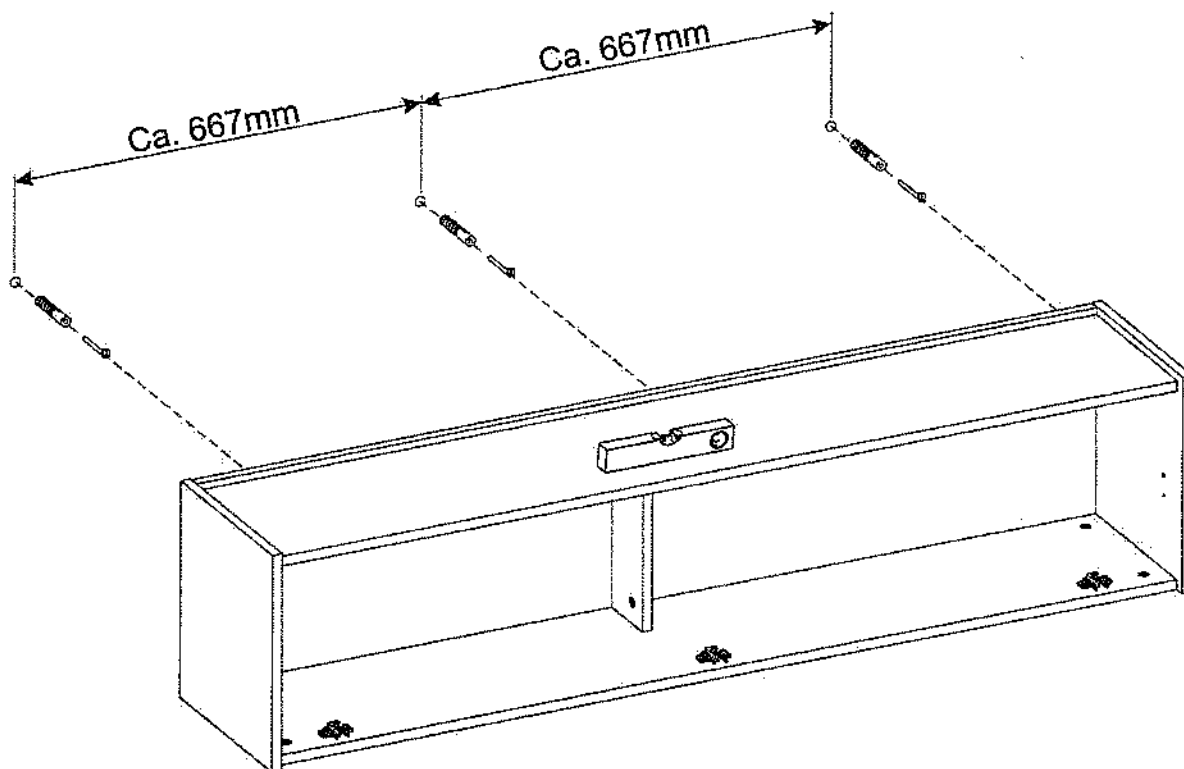
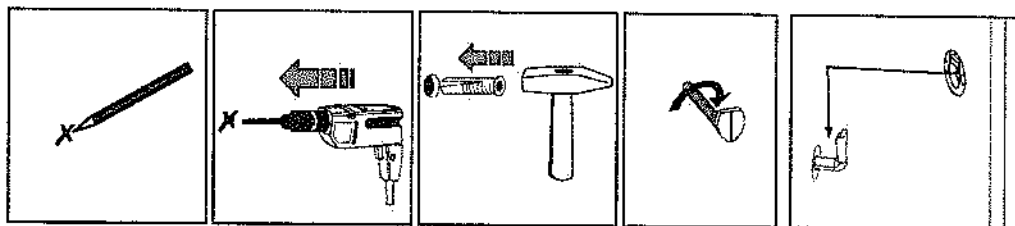
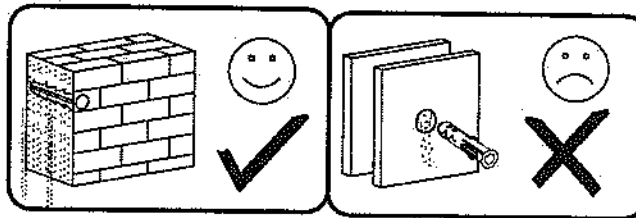
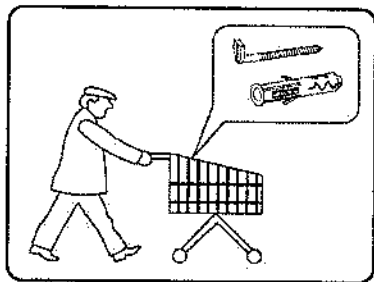

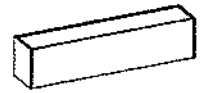

X

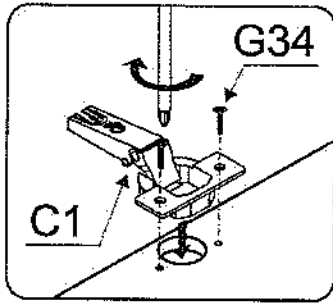

C1



x3

G34



3,5x16

x6

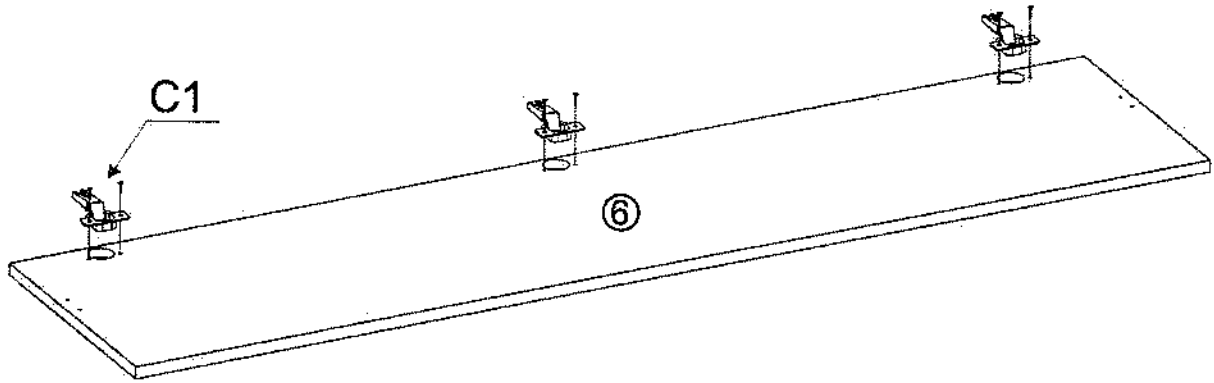

XI

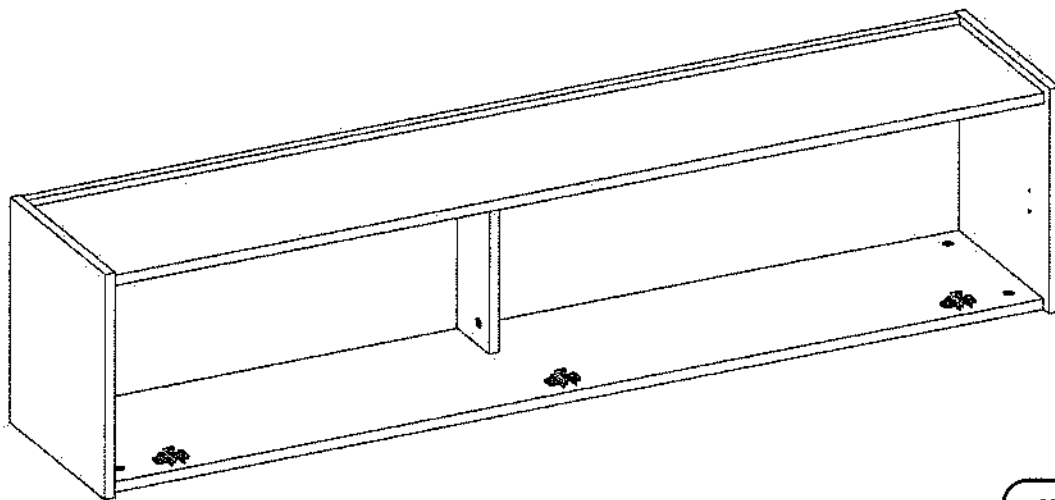

17

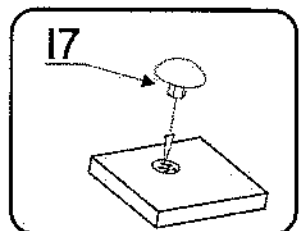

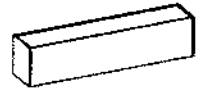

XII

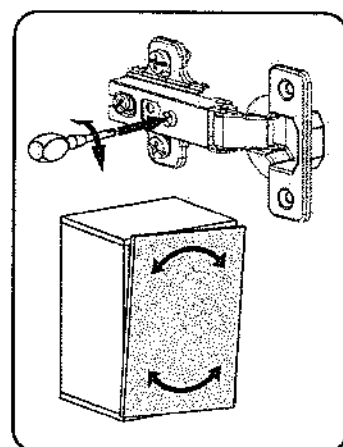
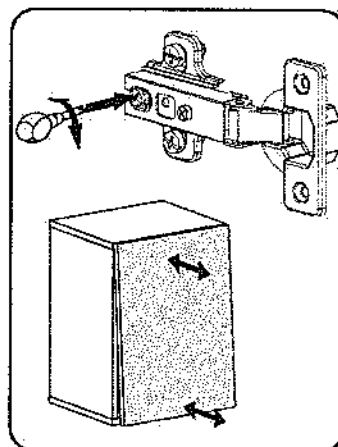
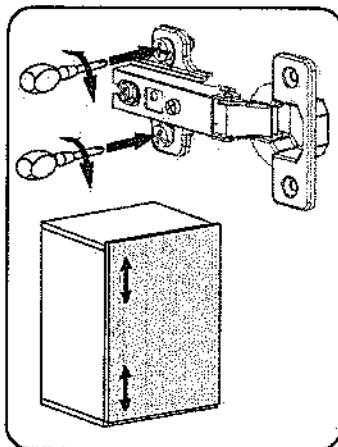
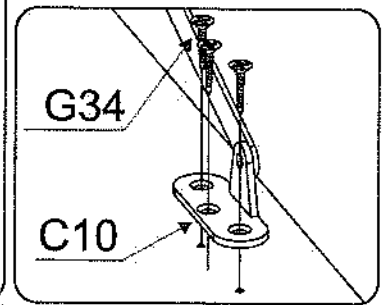
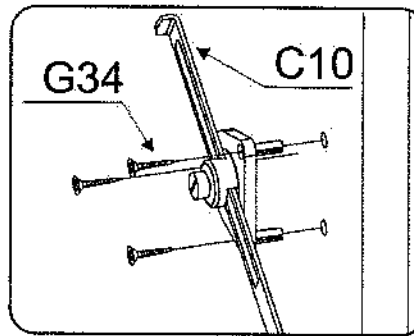
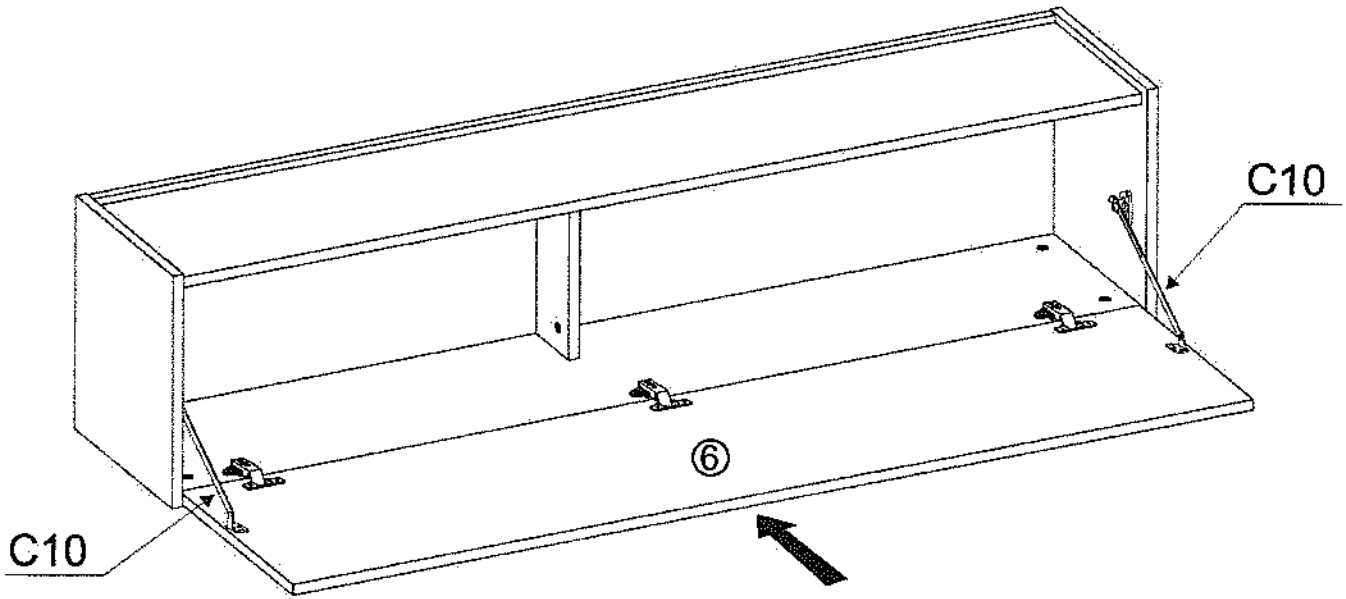
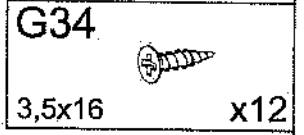
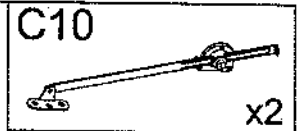
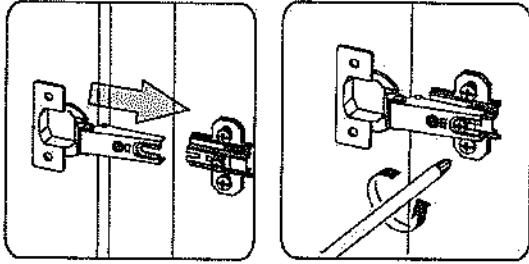

Name • Nom • Nome • Naam • Nazwa • Jméno
• Názov • Név • Denumire • Ísim • Имя

Nr • No • N° • Номер • Č • Sz

Typ • Type • Tip • Típus • Tipo • Tun

CITY / GIRON

46

Unser Direktservice für Beschädigte

Sollte Ihnen ein Beschädigter fehlen, können Sie diese Servicekarte direkt an die untenstehende Adresse mailen. Wir können allerdings nur Beschädigte auf diesem Wege verschicken. Sollten Sie eine andere Beanstandung an Ihrem Möbelstück haben, so wenden sie sich bitte direkt an Ihr Möbelhaus.

Our direct order service for fitting
If a fitting part is missing, you can e-mail this service card directly to the address below. However, we can only send fitting parts in this way. If you have any other cause for complaint concerning your item of furniture, please contact your furniture store directly.

Naša přímá služba pro kování
Chybí-li vám nějaký díl z kování, můžete tuto servisní kartu odeslat e-mailem přímo na níže uvedenou adresu. Touto cestou však můžeme rozeslat jen díly kování. Pokud byste reklamovali jiný díl nábytku, obraťte se přímo na svéto prodejce nábytku.

Bien étudier la notice de montage
Si vous manquez une ferrure, veuillez envoyer directement la présente carte service à l'adresse e-mail indiquée ci-dessous. Cependant, ceci nous permet uniquement d'envoyer des ferrures. Pour tout autre type de réclamation concernant votre meuble, veuillez contacter directement votre magasin d'ameublement.

Il nostro servizio diretto per l'ordine della ferramenta
Qualora Vi dovesse mancare un pezzo di fissaggio, allora Vi preghiamo di inviare questa carta di servizio immediatamente all'indirizzo sottostante. Possiamo inviare i pezzi di fissaggio solamente per mezzo di questo procedimento. Qualora dovete avere qualche altra reclamazione in merito al mobile, allora Vi preghiamo di rivolgerVi direttamente al Vostro Negozio di mobili.

Нашата директна услуга за обков
Ако липоват частик от кováнката, полъгнете настоящата сервисна карта и ни я изпратете на e-mail адреса, посочен по-долу. По този начин можем да доставим само липсващи елементи от обкова. Ако установите други дефекти по мебелите, ви съветваме да се обърнете към мебелната къща/магазин, от който сте закупили стоката.

Onze directservice voor losse onderdelen
Wanneer er een onderdeel ontbreekt, kunt u deze servicekaart direct aan onderstaand e-mailadres sturen. Wij kunnen langs deze weg echter alleen losse onderdelen versturen. Mocht u een ander probleem aan uw meubel hebben, verzoeken wij u contact op te nemen met uw meubeldealer.

Nasz bezpośredni serwis części montażowych
Jeżeli brakuje części koniecznych do montażu, prosimy o przesłanie nam niniejszej karty serwisowej na niżej podany adres e-mailowy. W ten sposób możemy przesyłać Państwu tylko brakujące części. W przypadku innych reklamacji dotyczących mebla, prosimy zgłosić się do salonu meblowego, w którym został dokonany zakup.

Служба за обкова
У случају да недостаје неки од делова молимо вас да на доје наведени mail адресу пошаљете овај сервисни образац. На овај начин могу се доставити само окови. У случају да имате додатне приговоре везане уз комад намештаја молимо вас да се обратите изравно трговини намештаја гдје је исти купљен.

Direktizogálátunk vasalatok esetén
Ha hiányzik egy vasalat, ezt e-kártyát közvetlenül elküldhetél az alább található címre. Azonban csak vasalatoskat tudunk így küldeni. Amennyiben másfajta reklamációt áll fenn bütörtarábját illetően, forduljon közvetlenül a bütörtárházhoz.

Náš priamy servis pre časti kovánia
Ak by Vám chýbala niejaká časť kovánia, môžete poslať túto servisnú kartu pošlať e-mailom na nižšie uvedenú adresu. Diely kovánia vieme pošlať iba týmto spôsobom. Ak by ste mali inú reklamáciu ohľadom Vášho nábytku, obraťte sa priamo na Vašu predajňu nábytku.

Naša direktna uslužna storitva za okovje
Če vam manjka kakšno okovje, lahko to servisno kartico pošljete po e-pošti direktno na spodnji naslov. Po tej poti vam lahko pošljemo samo okovje. Če želite reklamirati kakšen drug del pohištva, se obrnite neposredno na vašo trgovino pohištva.

Service-ul nostru direct pentru feronerie
In cazul in care va lipsesca o piesa de feronerie puteti sa trimitezi direct acest card de service prin e-mail la adresa de mai jos. Noi nu putem expedia piesa de feronerie decat pe aceasta cale. Dacã aveți o altã reclamatie referitoare la piesa de mobilier, atunci vã rugãm sã vã adresați direct la magazinul dvs. de mobilã.









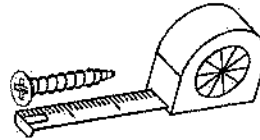

Наш прямой сервис для поставок фурнитуры
Если окажется, что Вам не хватает того или иного элемента фурнитуры, Вы можете отправить сервисную карту по факсу непосредственно на нижеприведенный адрес электронной почты. Однако, таким образом мы можем переслать лишь фурнитуру. Если же у Вас возникнут иные претензии относительно приобретенной мебели, пожалуйста, обращайтесь непосредственно в организацию, осуществившую продажу.

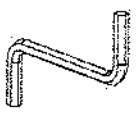
Vår directservice för beslagdelar
Om du saknar en beslagdel kan du skicka detta servicekort direkt till e-postadressen som anges nedan. Tänk på att detta är den enda möjligheten att skicka beslagdelar till dig. Om du vill reklamera din möbel av annan anledning måste du kontakta ditt möbelhus direkt.

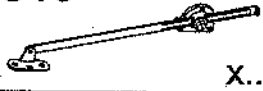
Nuestro servicio directo para accesorios
Si le falta algún accesorio, puede enviar esta tarjeta de servicio directamente a la siguiente dirección. No obstante, por este método solo podemos enviar accesorios. Si tiene alguna otra objeción sobre su mueble, consulte directamente con su mueblería.

Donatlar için doğrudan servisimiz
Bir donatınız eksikse bu servis kartını doğrudan aşağıdaki bulunan adrese doğrudan mail yazabilirsiniz. Sadece bu yolla donatıları gönderebiliriz. Mobilyanızda başka şikayetleriniz varsa lütfen doğrudan mobilya satışçınıza danışın.



B1  ø8x35 X...	A1  ø7x50 X...	W2  X...
I7  X...	K1  X...	C10  X...
K10  X...	D6  X...	C1  X...
G34  3,5x16 X...	P10  X...	G52  5x11 X...

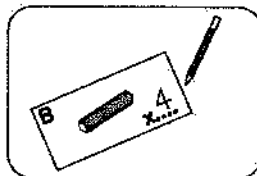

Name • Nom • Nome • Naam • Nazwa • Jméno
• Názov • Név • Denumire • İsim • Имя

Nr • No • N° • Номер • Č • Sz

Typ • Type • Tip • Түрүс • Типо • Tun

CITY / GIRON

46

Uner Direktservice für Beschläge

Sollte Ihnen ein Beschlagteil fehlen, können Sie diese Servicekarte direkt an die untenstehende Adresse mailen. Wir können allerdings nur Beschläge auf diesem Wege verschicken. Sollten Sie eine andere Beanstandung an Ihrem Möbelstück haben, so wenden Sie sich bitte direkt an Ihr Möbelhaus.

D

Our direct order service for fitting

If a fitting part is missing, you can e-mail this service card directly to the address below. However, we can only send fitting parts in this way. If you have any other cause for complaint concerning your item of furniture, please contact your furniture store directly.

GB

Neste přímá služba pro kování

Chybí-li vám nějaký díl z kování, můžete tuto servisní kartu odeslat e-mailem přímo na níže uvedenou adresu. Toulou cestou však můžeme zrealizovat jen díly kování. Pokud byste reklamovali jiný díl nábytku, obraťte se přímo na svého prodejce nábytku.

CZ

Bien étudier la notice de montage

Si vous manquez une ferrure, veuillez envoyer directement la présente carte service à l'adresse e-mail indiquée ci-dessous. Cependant, ceci nous permet uniquement d'envoyer des ferrures. Pour tout autre type de réclamation concernant votre meuble, veuillez contacter directement votre magasin d'ameublement.

F

Il nostro servizio diretto per l'ordine della ferramenta

Qualora Vi dovesse mancare un pezzo di fissaggio, allora Vi preghiamo di inviare questa carta di servizio immediatamente all'indirizzo sottostante. Possiamo inviare i pezzi di fissaggio solamente per mezzo di questo procedimento. Qualora dovesse avere qualche altra reclamazione in merito al mobile, allora Vi preghiamo di rivolgerVi direttamente al Vostro Negozio di mobili.

I

Нашата директна услуга за обкоа

Ако липсват части от комплекта, попълнете настоящата сервисна карта и ни я изпратете на e-mail адреса, посочен по-долу. По този начин можем да доставяме само липсващи елементи от обкоа. Ако установите други дефекти по мебелите, Ви съветваме да се обърнете към мебелната къща/магазин, от който сте закупили стоката.

BG

Onze directservice voor losse onderdelen

Wanneer er een onderdeel ontbreekt, kunt u deze servicekaart direct aan onderstaand e-mailadres sturen. Wij kunnen langs deze weg echter alleen losse onderdelen versturen. Mocht u een ander probleem aan uw meubel hebben, verzoeken wij u contact op te nemen met uw meubeldealer.

NL

Nasz bezpośredni serwis części montażowych

Jeżeli brakuje części koniecznych do montażu, prosimy o przesłanie nam niniejszej karty serwisowej na niżej podany adres e-mailowy. W ten sposób możemy przelać Państwu tylko brakujące części. W przypadku innych reklamacji dotyczących mebla, prosimy zgłosić się do salonu meblowego, w którym został dokonany zakup.

PL

Сervis за okova

U slučaju da nedostaje neki od dijelova molimo vas da na doje navedenu mail adresu pošaljete ovaj servisni obrazac. Na ovaj način mogu se dostaviti samo okovi. U slučaju da imate dodatne prigovore vezane uz komad namještaja molimo vas da se obratite izravno trgovini namještaja gdje je isti kupljen.

HR

Direktszolgáltatunk vasalatok eszlen

Ha hiányzik egy vasalat, ezt a kártyát közvetlenül elküldheti az alább látható címre. Azonban csak a vasalatokat tudunk így küldeni. Amennyiben másfajta reklamációt áll fenn bútorárbájét illetően, forduljon közvetlenül a bútorházhöz.

HU

Náš priamy servis pre časti kovania

Ak by Vám chýbalo nejaká časť kovania, môžete poslať túto servisnú kartu pošťou e-mailom na nižšie uvedenú adresu. Díly kovania vieme poslať iba týmto spôsobom. Ak by ste mali inú reklamáciu ohľadom Vášho nábytku, obraťte sa priamo na Vašu predajňu nábytku.

SK

Naste direktna uslužna služba za okovje

Če vam manjka kakšno okovje, lahko to servisno kartico pošljete po e-pošti direktno na spodnji naslov. Po tej poti vam lahko pošljemo samo okovje. Če želite reklamirati kakšen drug del pohištva, se obrnite neposredno na vašo trgovino pohištva.

SLO

Service-ul nostru direct pentru feronerie

În cazul în care vă lipsește o piesă de feronerie puteți să trimiteți direct acest card de service prin e-mail la adresa de mai jos. Noi nu putem expedia piese de feronerie decât pe această cale. Dacă aveți o altă reclamație referitoare la piesa de mobilier, atunci vă rugăm să vă adresați direct la magazinul dvs. de mobilier.

RO

Наша прямой сервис для поставок фурнитуры

Если окажется, что Вам не хватает того или иного элемента фурнитуры, Вы можете отправить сервисную карту по факсу непосредственно на нижеприведенный адрес электронной почты. Однако, таким образом мы можем пересылать лишь фурнитуру. Если же у Вас возникнут иные претензии относительно приобретенной мебели, пожалуйста, обращайтесь непосредственно в организацию, осуществившую продажу.

RUS

Vår direktservice för beslagsdelar

Om du saknar en beslagsdel kan du skicka detta servicekort direkt till e-postadressen som anges nedan. Tankt på att detta är den enda möjligheten att skicka beslagsdelar till dig. Om du vill reklamera din möbel av en annan anledning måste du kontakta ditt möbelfus direkt.

S

Nuestro servicio directo para accesorios

Si le falta algún accesorio, puede enviar esta tarjeta de servicio directamente a la siguiente dirección. No obstante, por este método solo podemos enviar accesorios. Si tiene alguna otra objeción sobre su mueble, consulte directamente con su mueblería.

ES

Donatlar için doğrudan servisimiz

Bir donatınız eksikse bu servis kartını doğrudan aşağıda bulunan adrese doğrudan mail yazabilirsiniz. Sadece bu yolla donatıları gönderebiliriz. Mobilyanızda başka şikayetiniz varsa lütfen doğrudan mobilya satıcınıza danışın.

TR

nr	L[mm]	B[mm]	T[mm]	Menge	Coil
1	350	300	16	1	1/1
2	350	300	16	1	1/1
3	305	100	16	1	1/1
4	1468	266	16	1	1/1
5	1468	283	16	1	1/1
6	1463	347	16	1	1/1
7	1468	332	16	1	1/1

