

TOLEDO WM 07

PL Instrukcja montażu

CZ Návod k montáži

D Montageanleitung

GB Assembly instruction

F Model d'emploi

HU Szerelési útmutató

I Istruzione di montaggio

NL Handleiding voor de montage

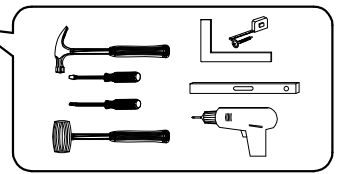
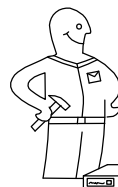

RU Инструкция по монтажу

RO Instrucțiuni de montare

SK Návod k montáži

TR Montaj talimatı

⚠ Uwaga • Upozornění • Achtung • Attention • Caution • Figyelem
Attenzione • Opgelet • Внимание • Atenție • Upozornenie • Dikkat ⚠

PL Czyszczenie należy wykonać wyłącznie za pomocą ściereczki lub lekko nawilżonego ręcznika. Nie stosować środków czyszczących do szorowania.

CZ Čistění je nutné vykonávat výhradně pomocí utěrky nebo lehkce navlhčeného ručníku. Nepoužívejte čisticí prostředky obsahující abrazivní částice.

D Bitte nur mit einem Staubtuch oder leicht feuchtem Lappen reinigen. Keine scheuernden Putzmittel verwenden.

GB Please only clean with a duster or a damp cloth. Do not use any abrasive cleaners.

F Le nettoyage se fait uniquement à l'aide d'un torchon ou d'une serviette légèrement mouillée.

HU A tisztítás kizárólag törölrúha vagy enyhén nedvesített törölköző segítségével végezhető. Súroló hatású tisztítószerket nem szabad használni.

I Pulire esclusivamente con un panno o un asciugamano umido.

NL Reinig alleen met een stofdoek of een lichtjes vochtige doek. Gebruik geen schurende poetsmiddelen.

RU Очищайте от пыли тряпкой или слегка влажной ветошью. Не допускается применение чистящих средств, не предназначенных для ухода за мебелью.

RO Curățarea trebuie efectuată numai cu o cârpă sau cu un prosop ușor umezit. Nu utilizați agenți de curățare abrazivi.

SK Čistění je nutné vykonávat výhradně pomocí utierky alebo ľahko zvlhnutým ručníkom. Nepoužívajte čistiace prostriedky obsahujúce abrazívne častice.

TR Lütfen sadece bir toz bezilye veya hafif nemli yumuşak bir bezle siliniz. Aşındırıcı temizlik malzemeleri kullanmayınız.

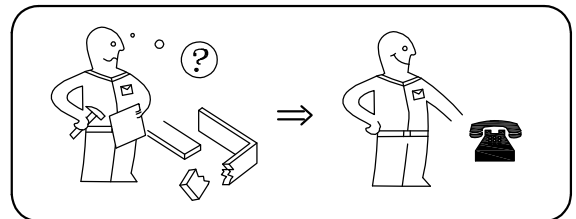
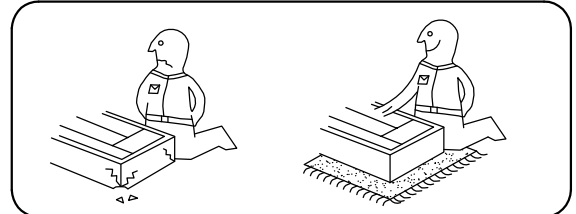

L

R

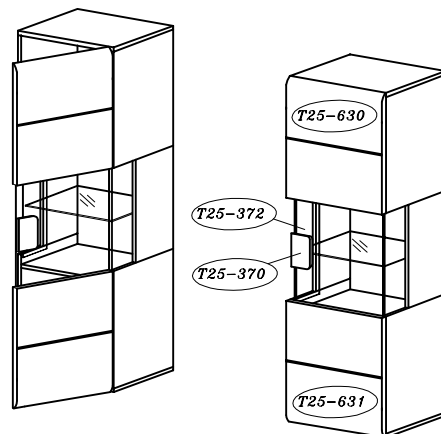
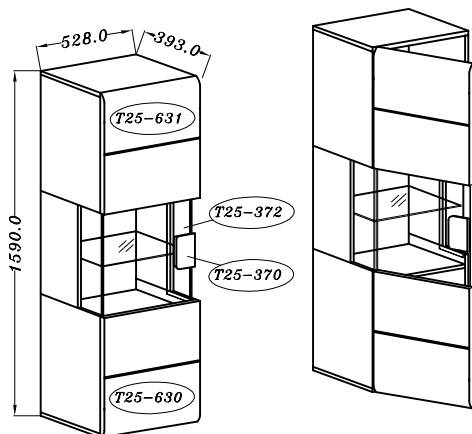

TOLEDO WM 07

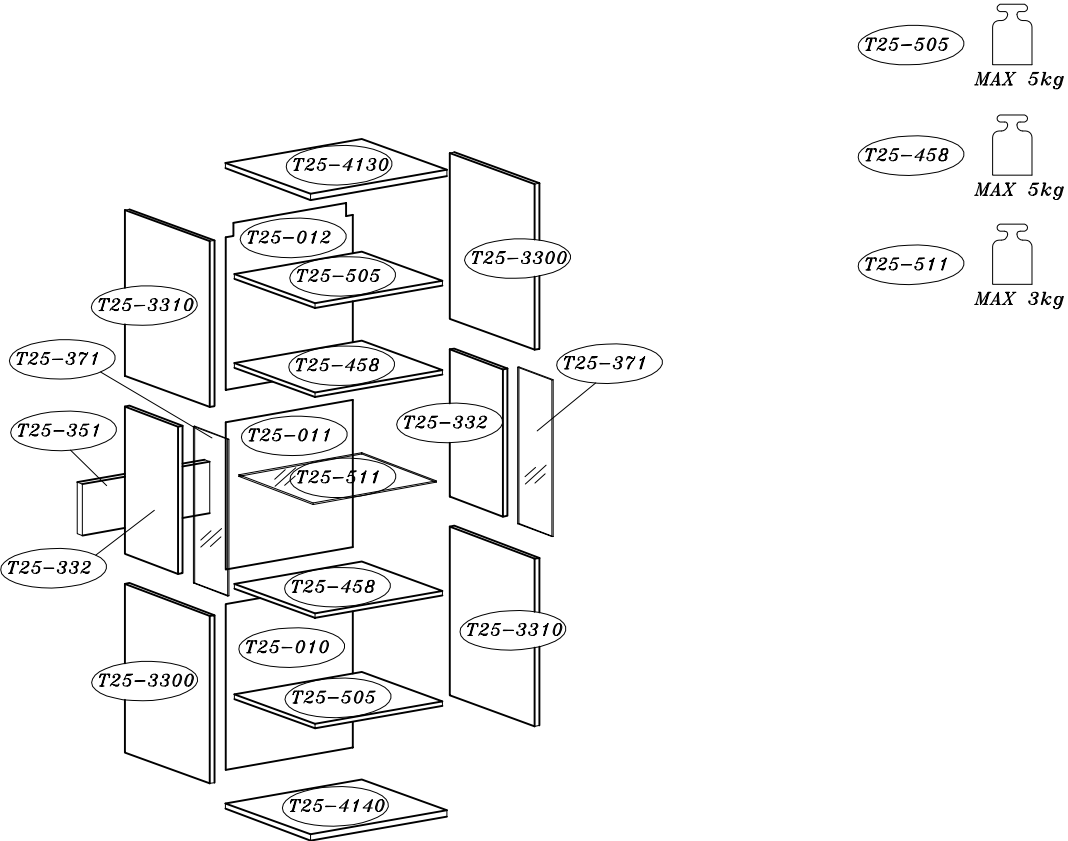
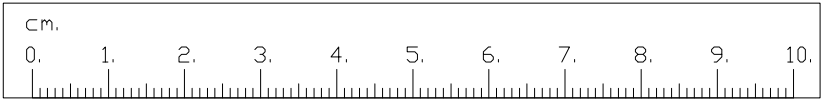
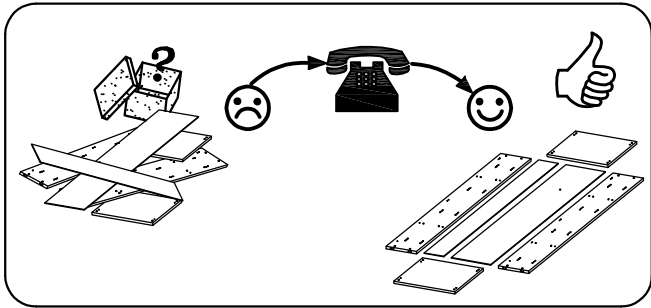
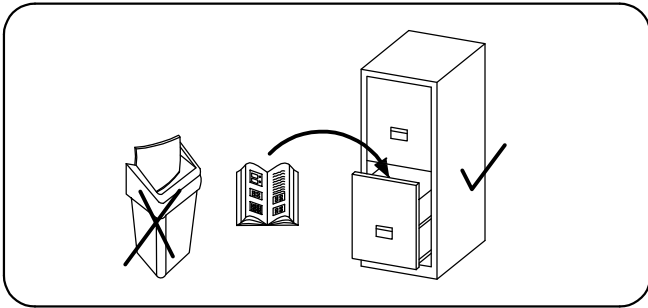

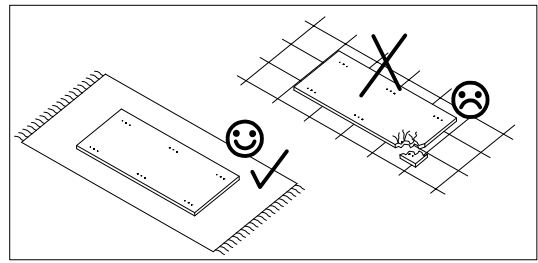
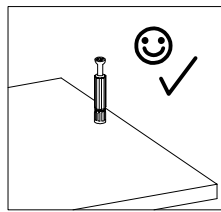
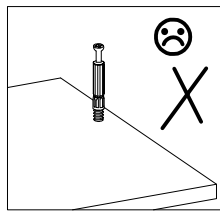
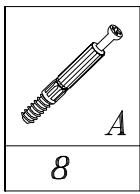

 6.4X50 K1	 4mm K3	 S									
2	1	2									
 A	 B	 C	 8.0x30 D	 M	 3.5x16 E1	 K	 Q	 4.0x20 G	 V1	 H	
18	34	26	20	7	10	4	10	2	8	8	
 4.0x13 N	 X	 KR-0 K	 J	 E	 L R V	 L R Q	 3.0X15 P1	 8.0x60 D1			
8	4	4	12	8	1 KPL	1 KPL	8	8			



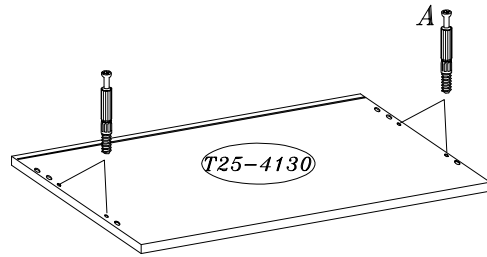
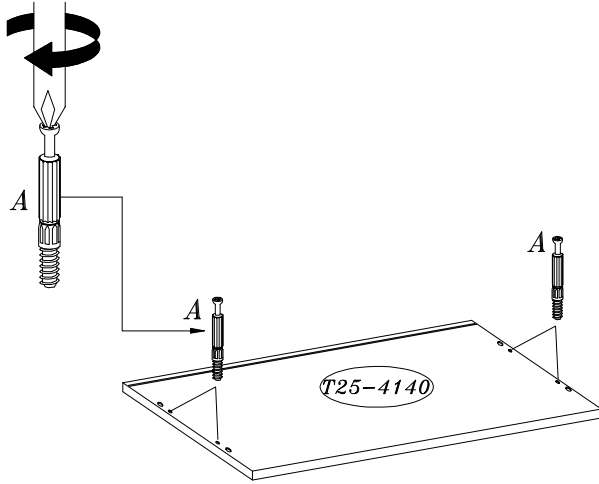



1



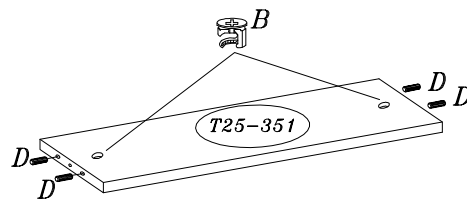
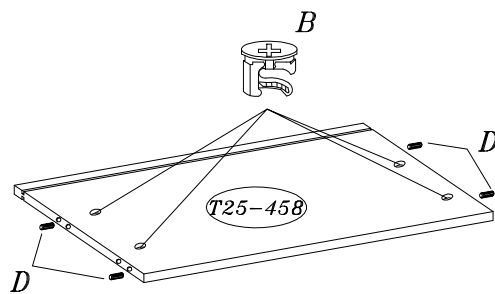
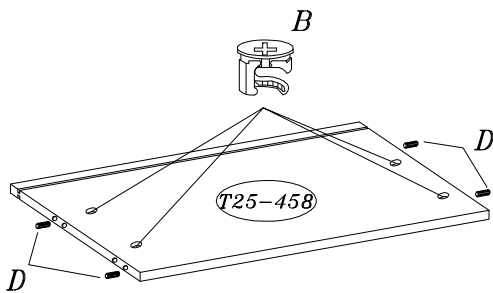

8.0x30	
	B
12	10

2

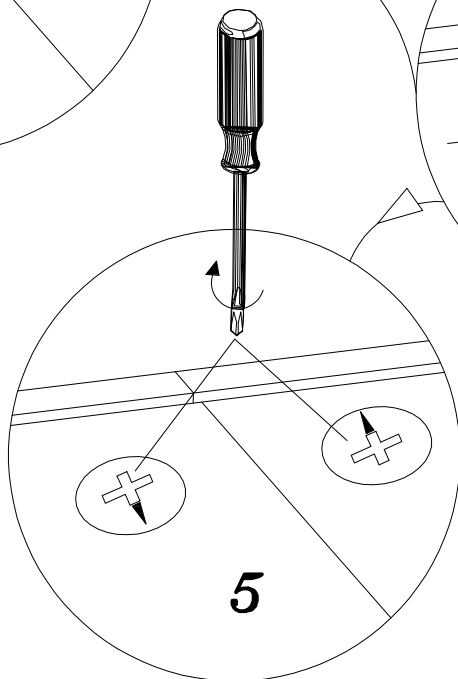
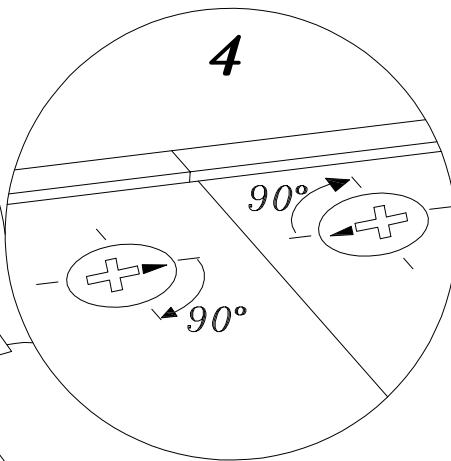
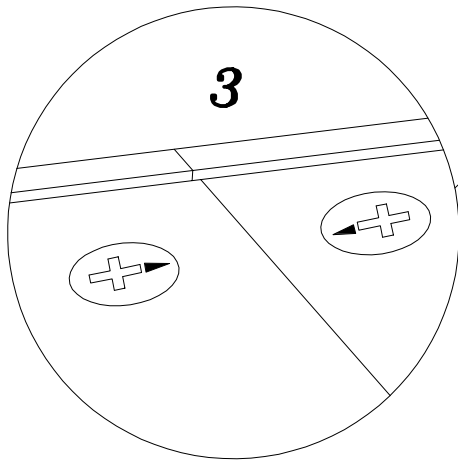
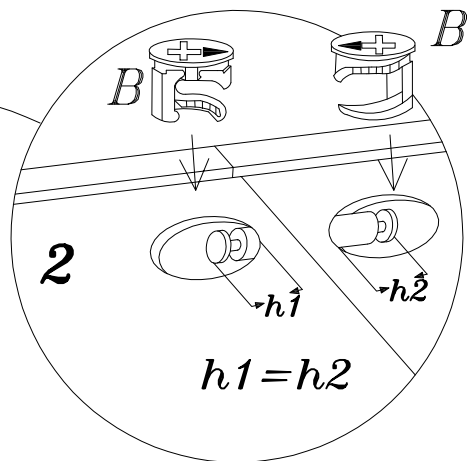
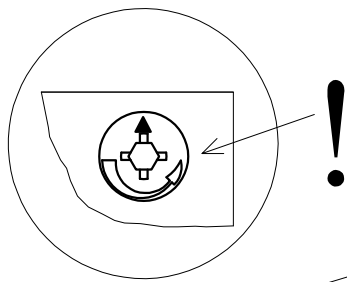
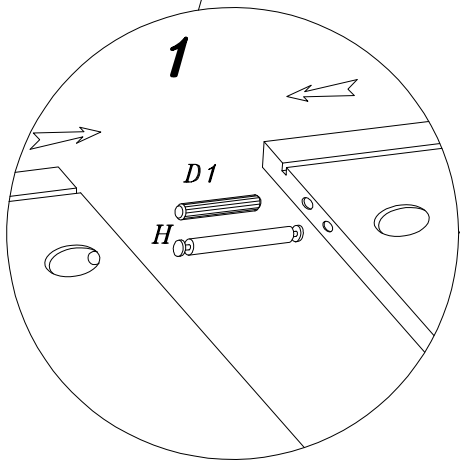
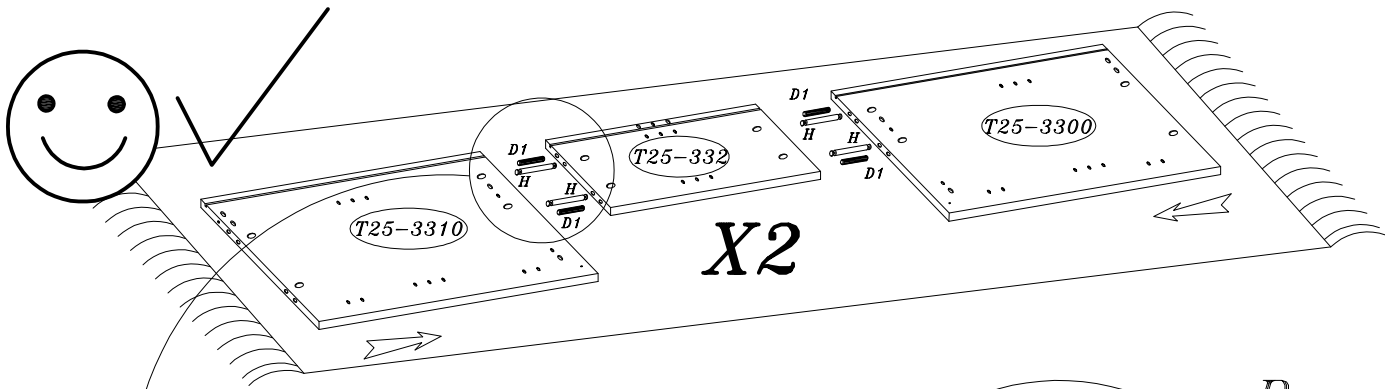
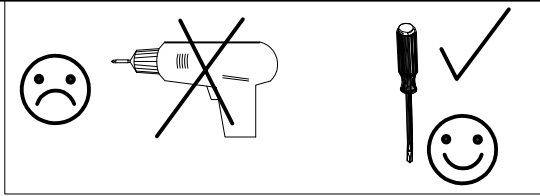

		8.0x60 
B	H	D1
16	8	8



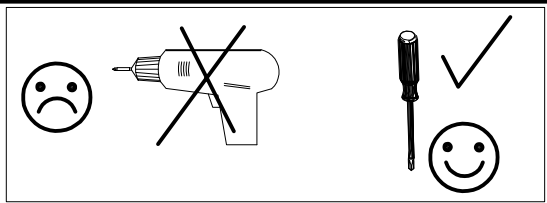
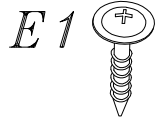

3.5x16	
 E1	Q
4	4

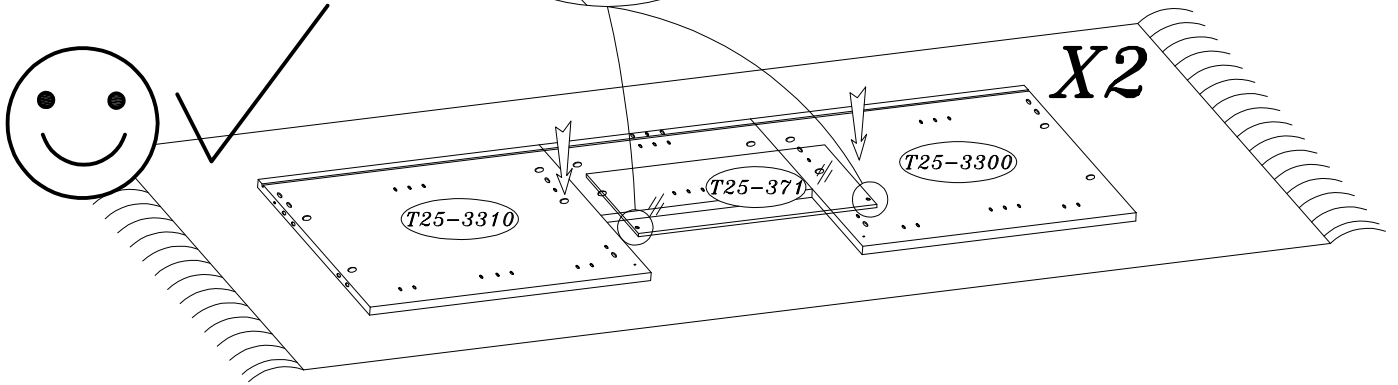
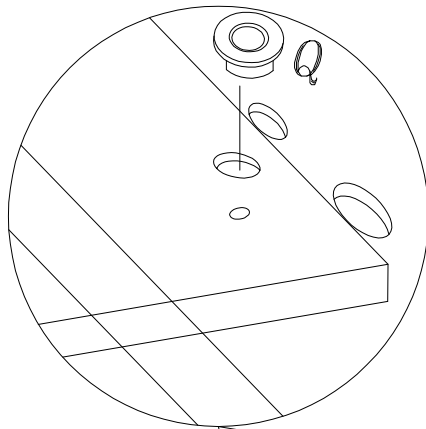

4



3.0x15	
 P1	V1
8	8

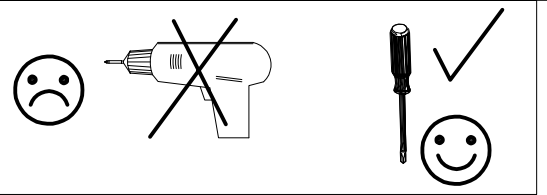
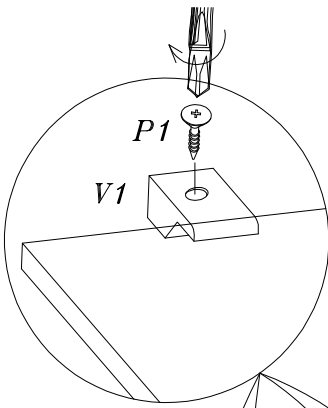

5

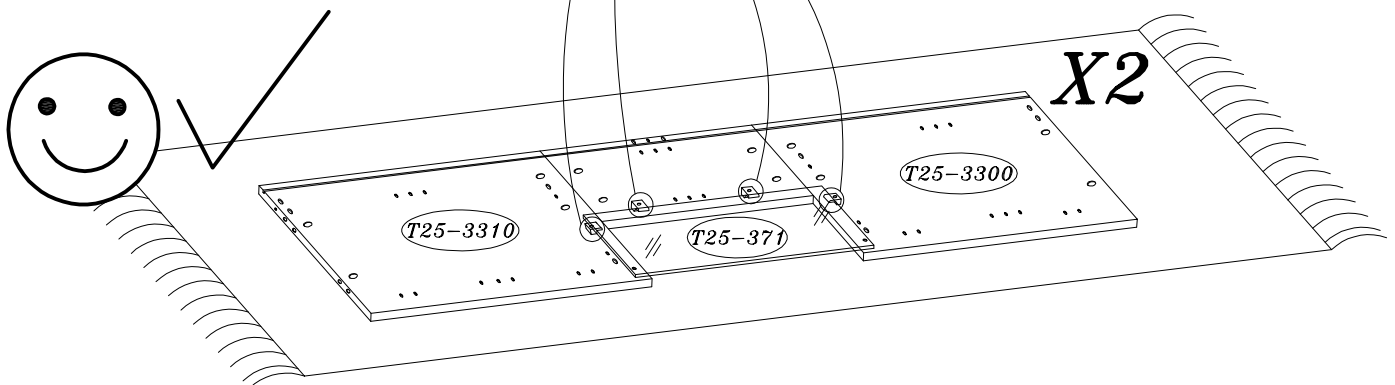

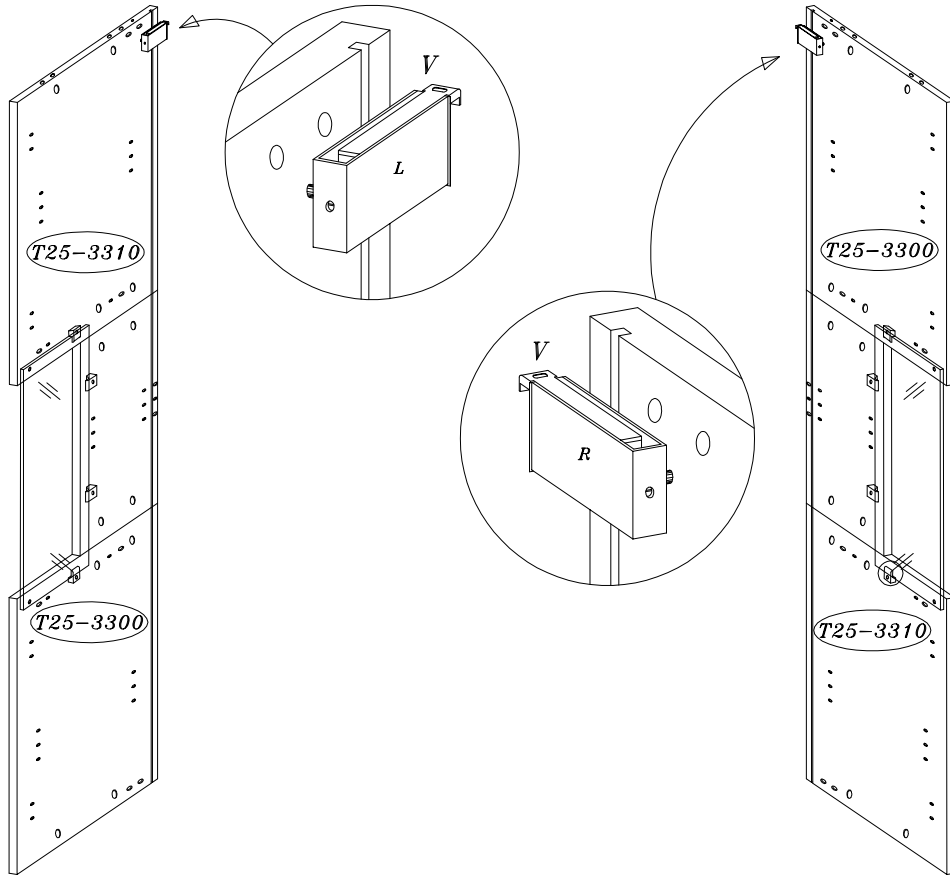
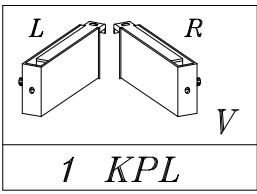

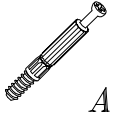
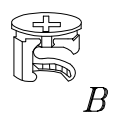
		8.0x30
A	B	D
10	8	8

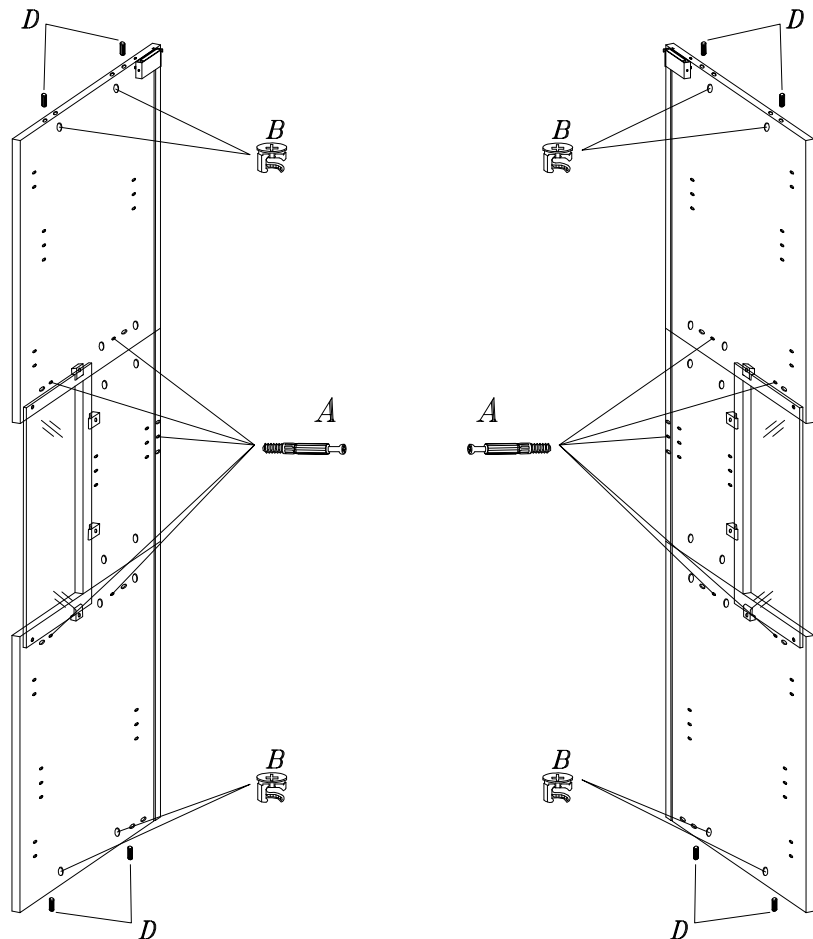

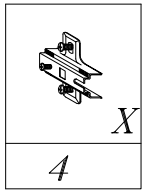

L

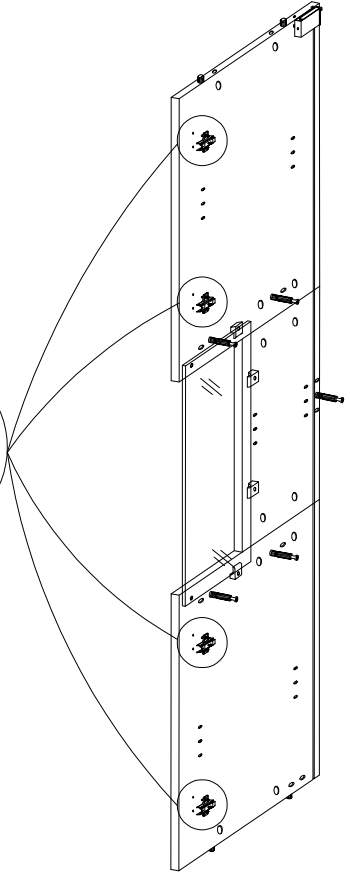
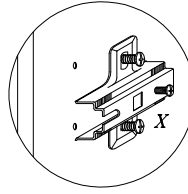
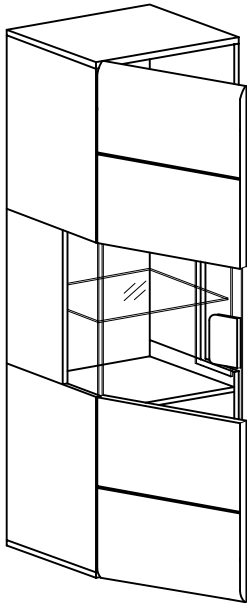

L/R

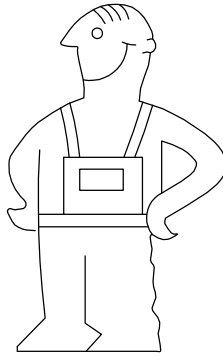



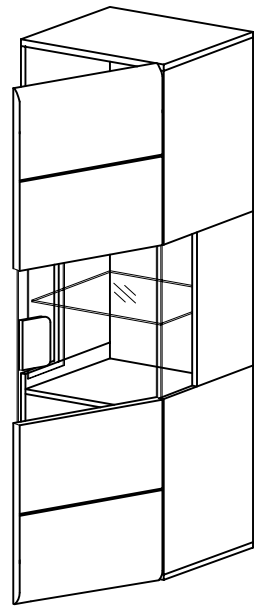
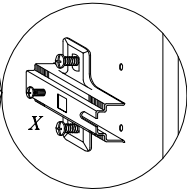
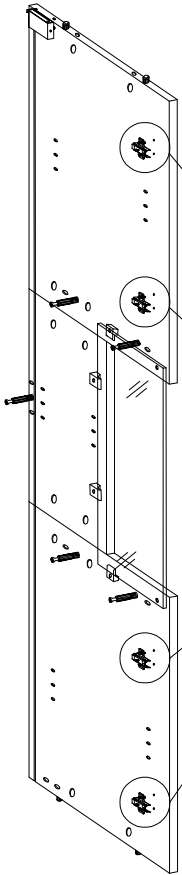

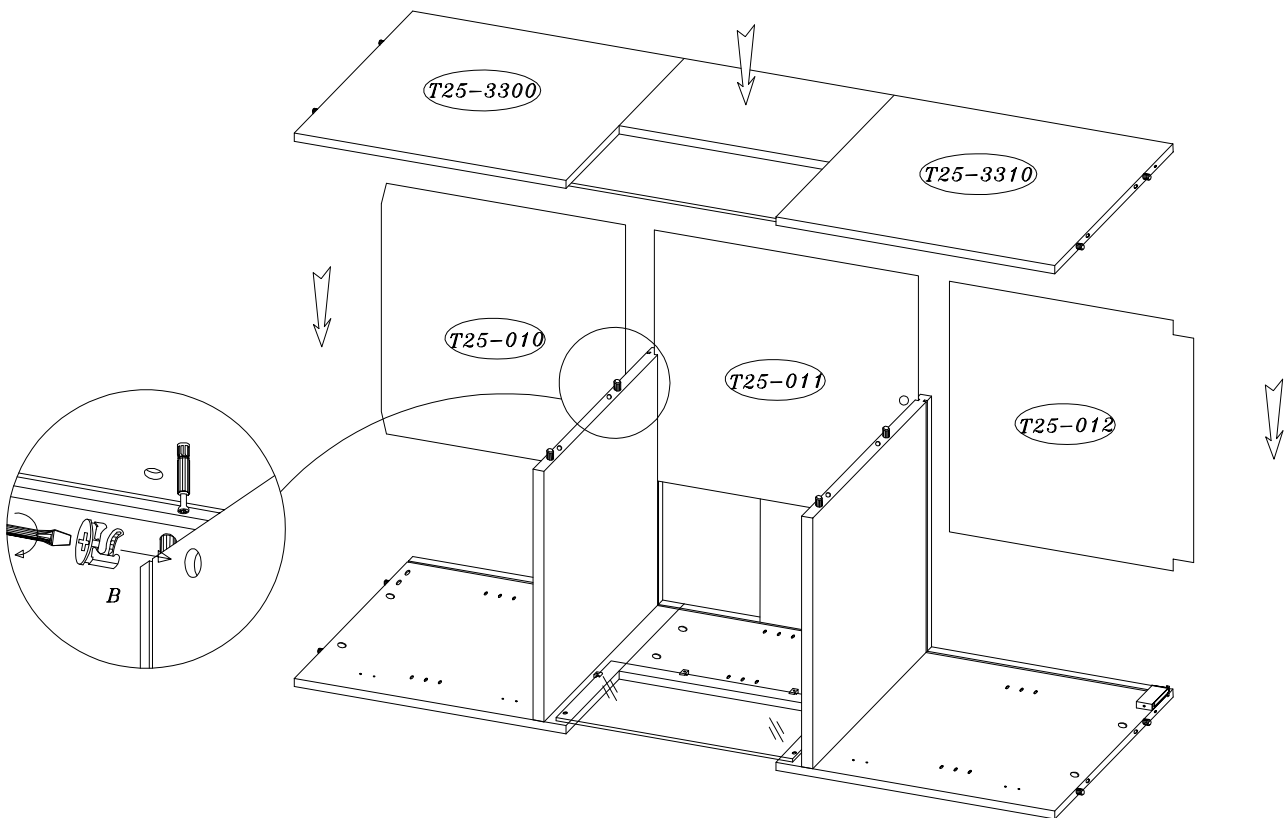
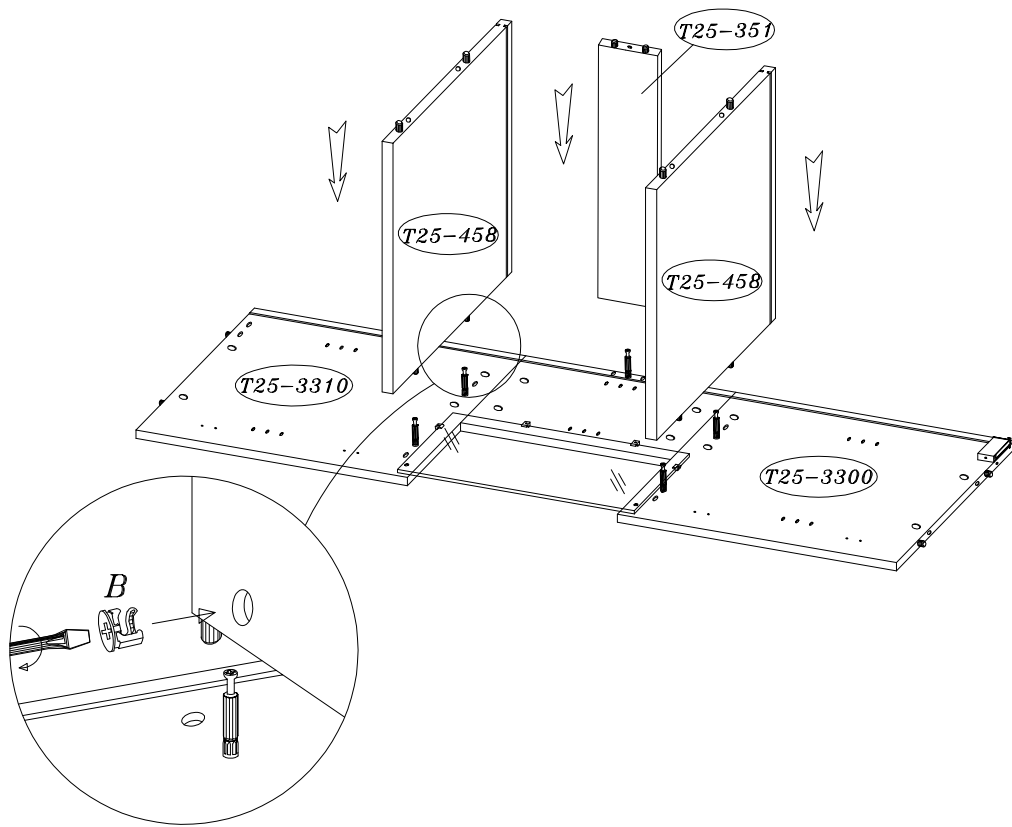
R

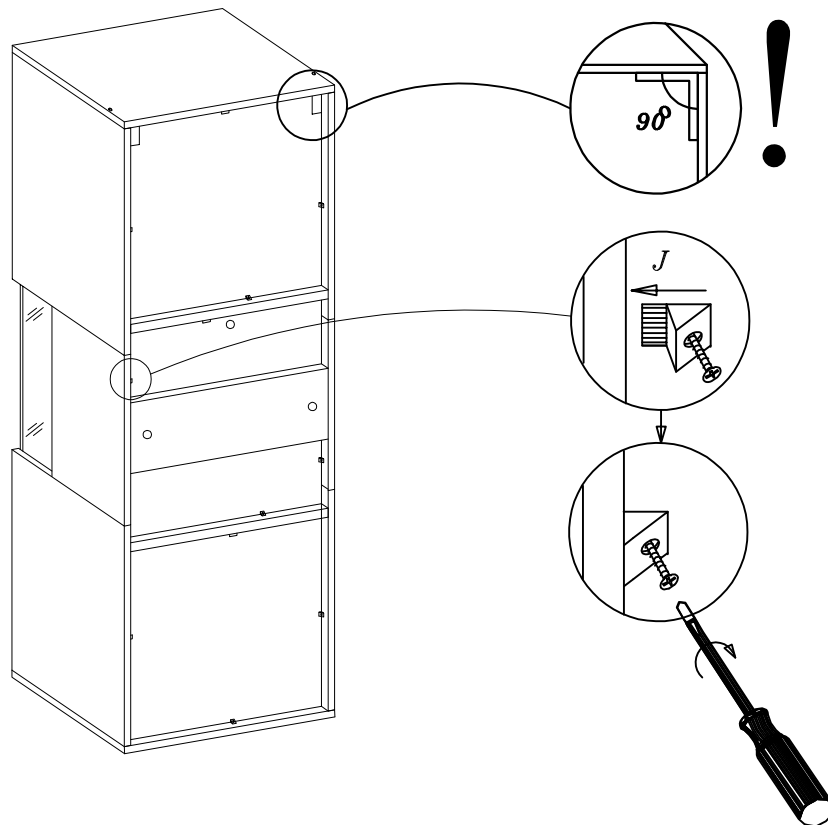
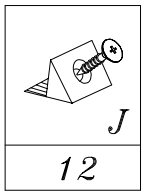
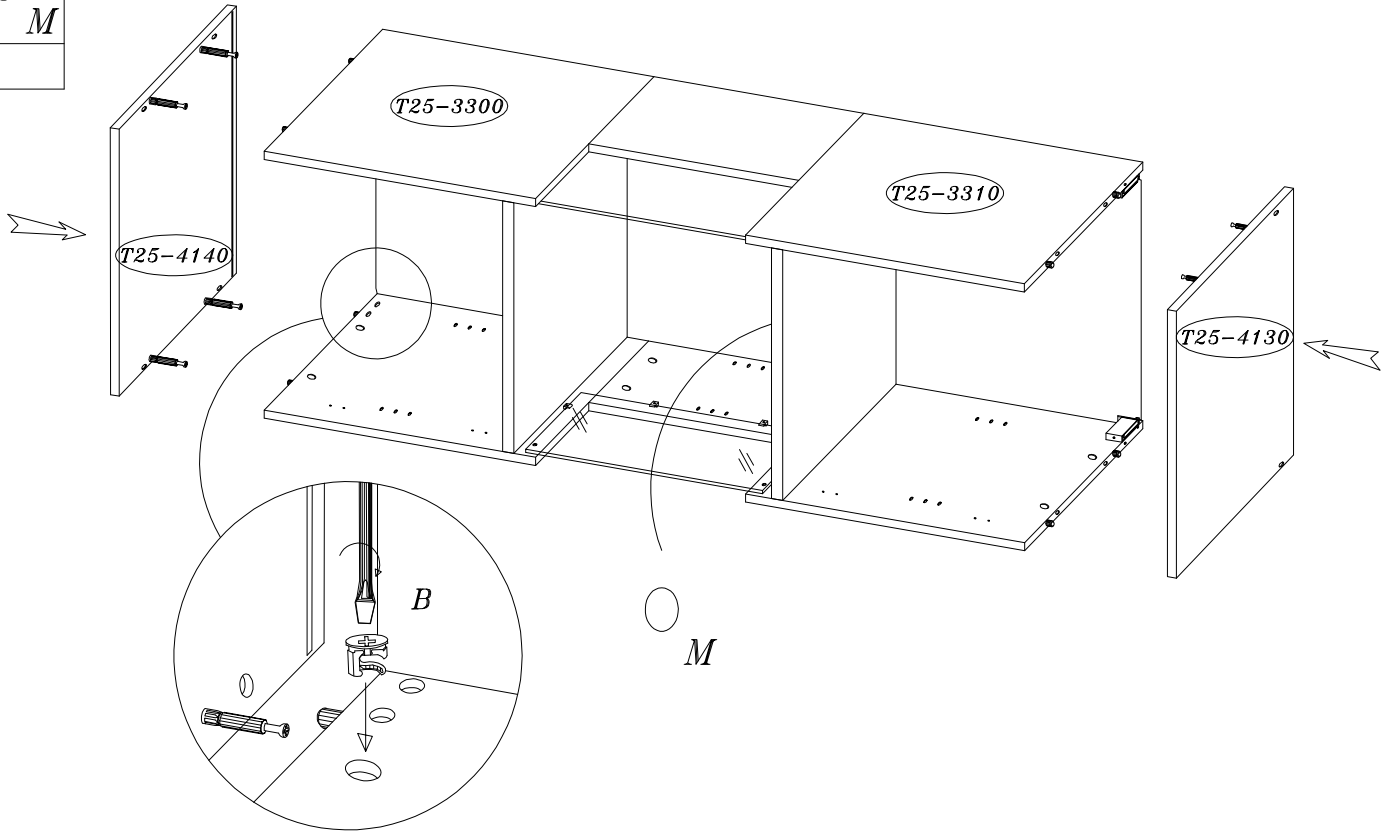
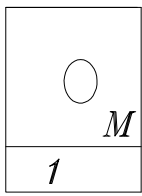

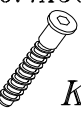

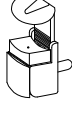

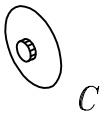

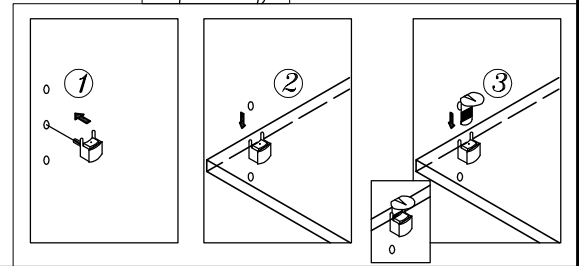
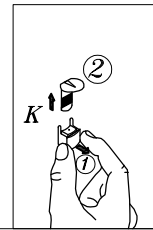
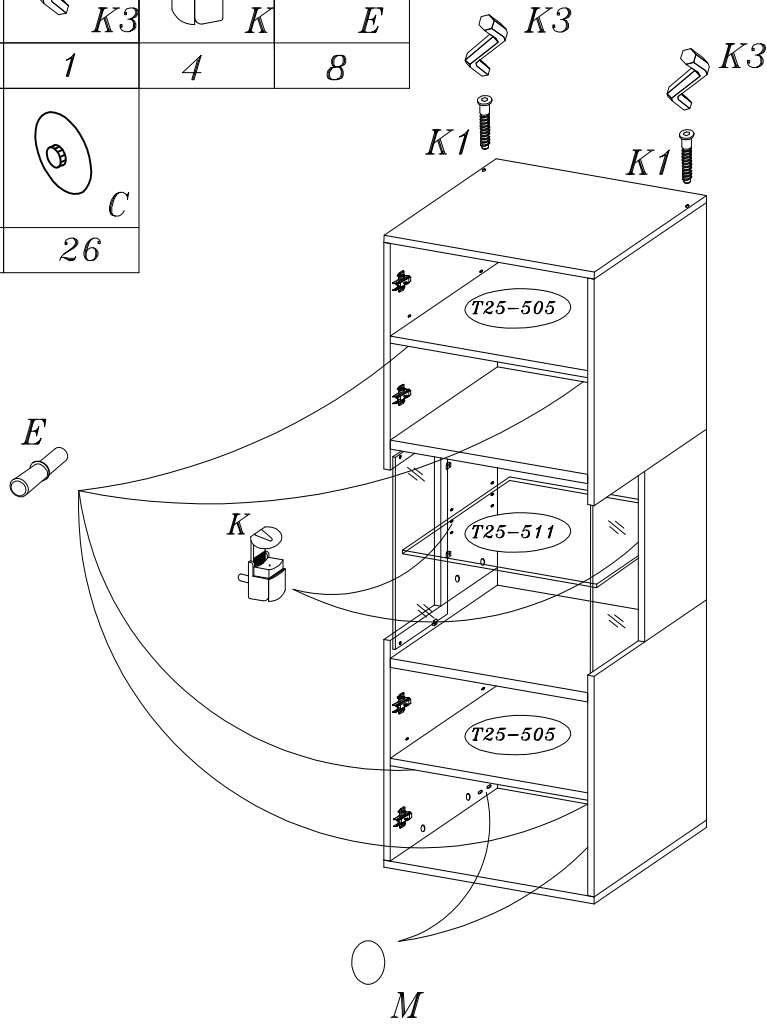



6.4X50  K1 2	4mm  K3 1	 K 4	 E 8
 M 4	 C 26		

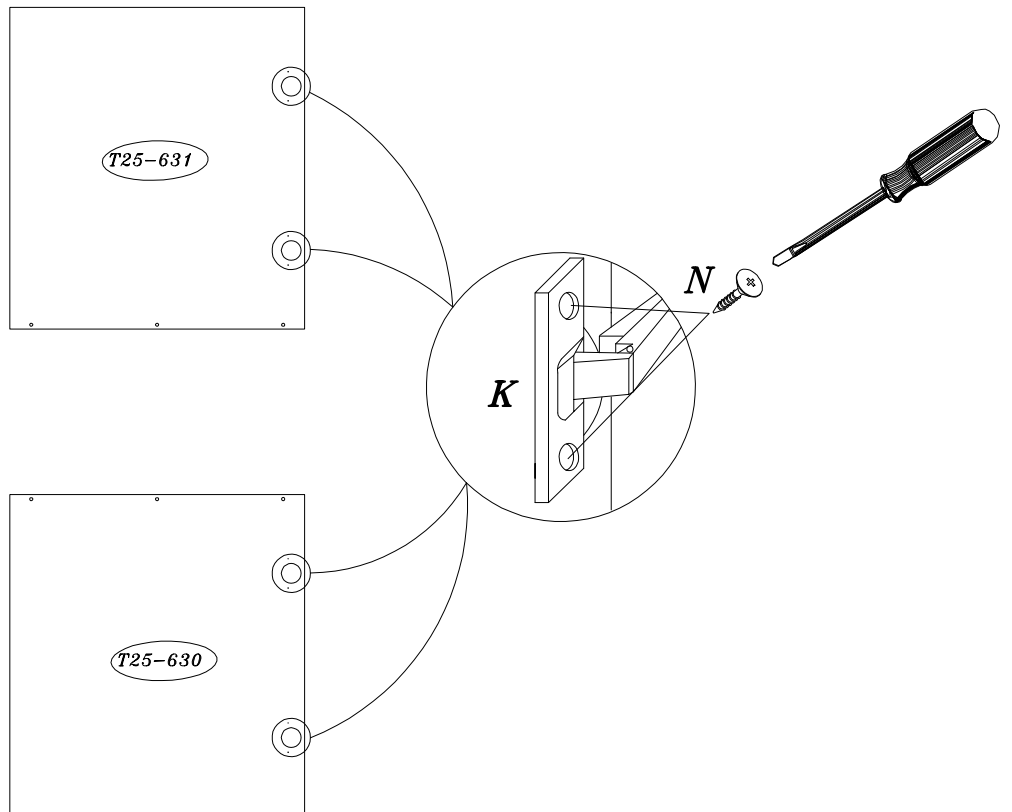

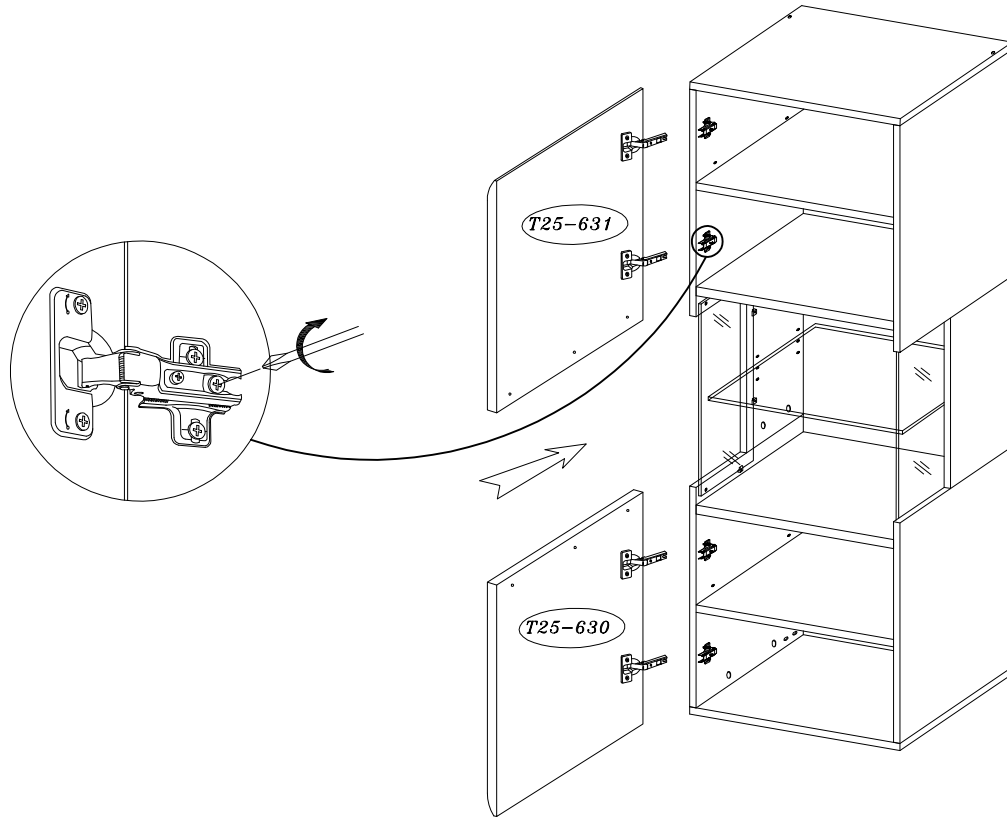
KR-0  K 4	4.0x13  N 8
------------------------------------------------------------------------------------------------------	---------------------------------------------------------------------------------------------------------





	3.5x16 	4.0x20 	
Q	E1	G	S
6	6	2	2

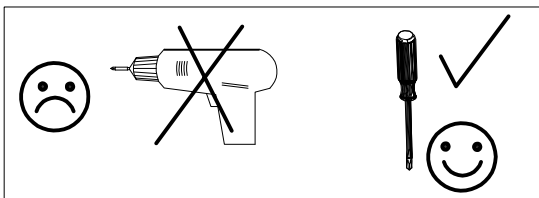
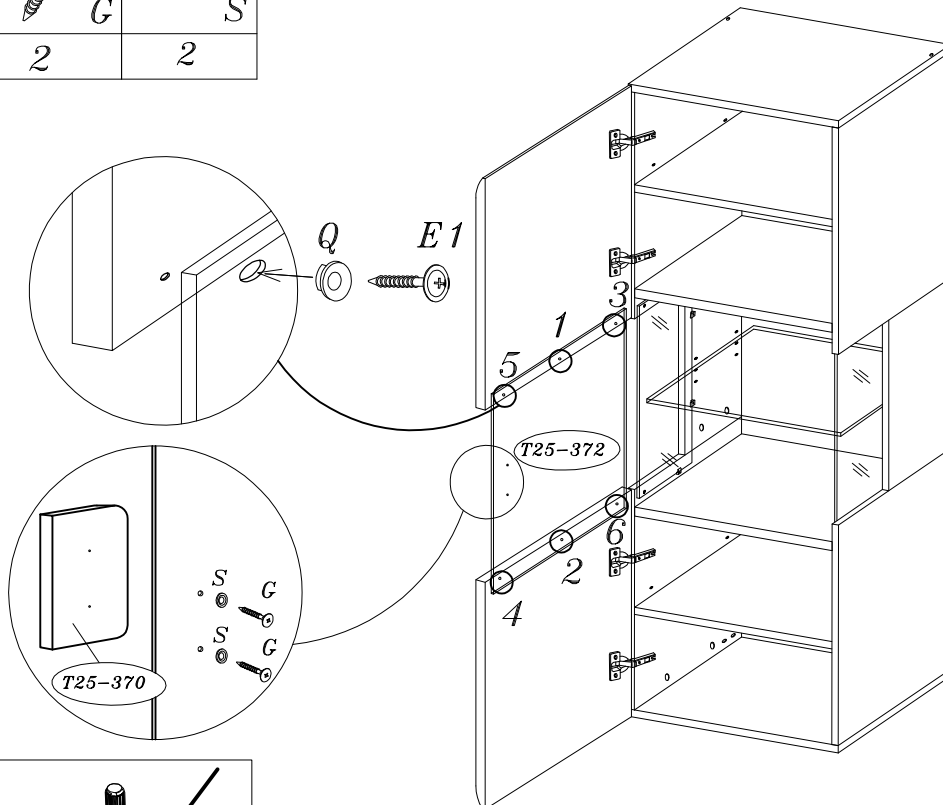

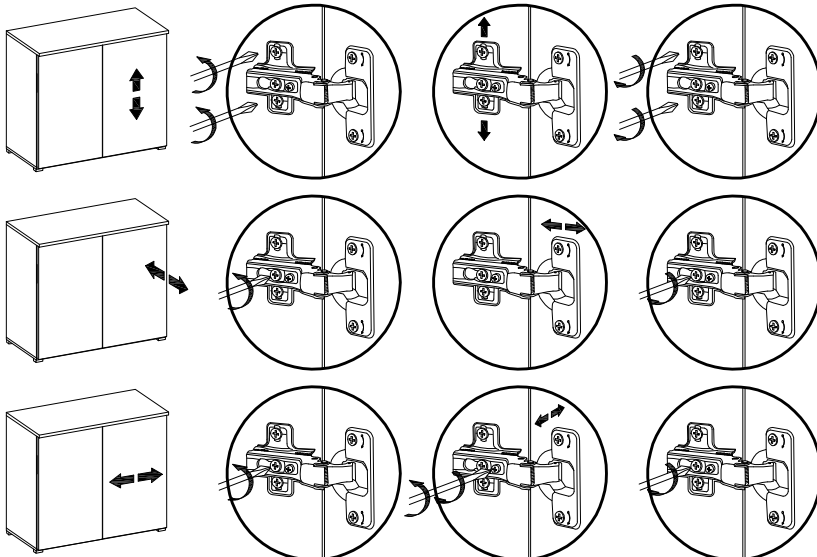
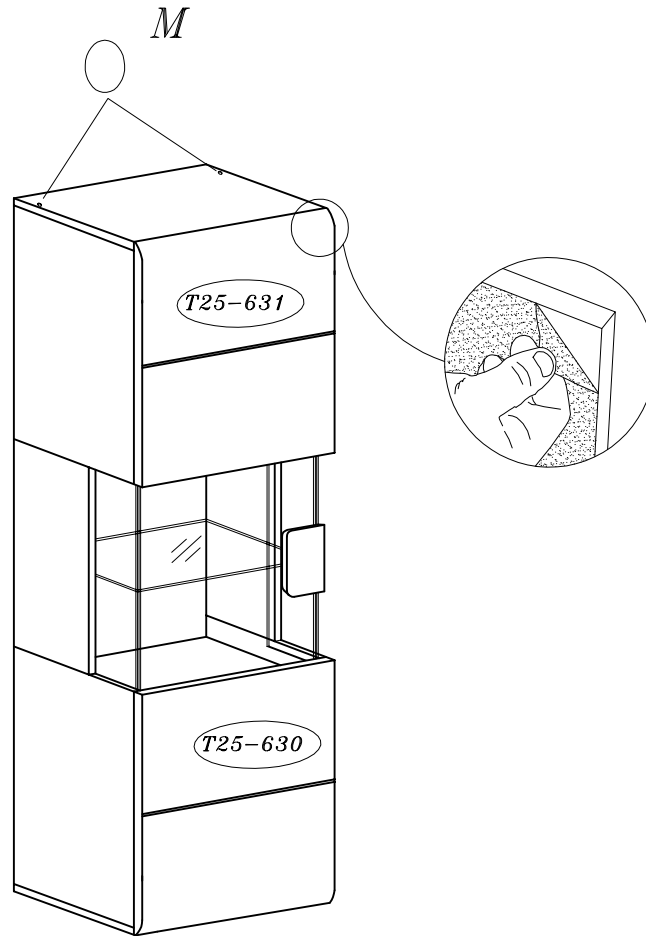
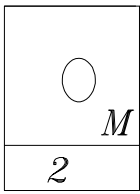

- (F) Mettre la porte (égaler les gonds)
- (I) Regolare la porta (livellare le parentesi)
- (D) Türen einstellen (Scharniere justieren)
- (GB) Adjusting the doors (adjusting the hinges)
- (NL) Deuren instellen (scharnieren afstellen)
- (PL) Nastawic drzwi (wyrownac zawiasy)
- (TR) Kapilarin ayarlanmasi (menteşelerin seviye ayari)
- (RU) Регулировка дверей (регулировка шарнира)
- (RO) Ajustați ușa (aliniati balamalele)
- (CZ) Seřid'te dveře (vyrovnejte závěsy)
- (SK) Zrad'te dvere (vyrovnajte závesy)
- (HU) Állítsa be az ajtót (igazítsa be a zsanérokot)

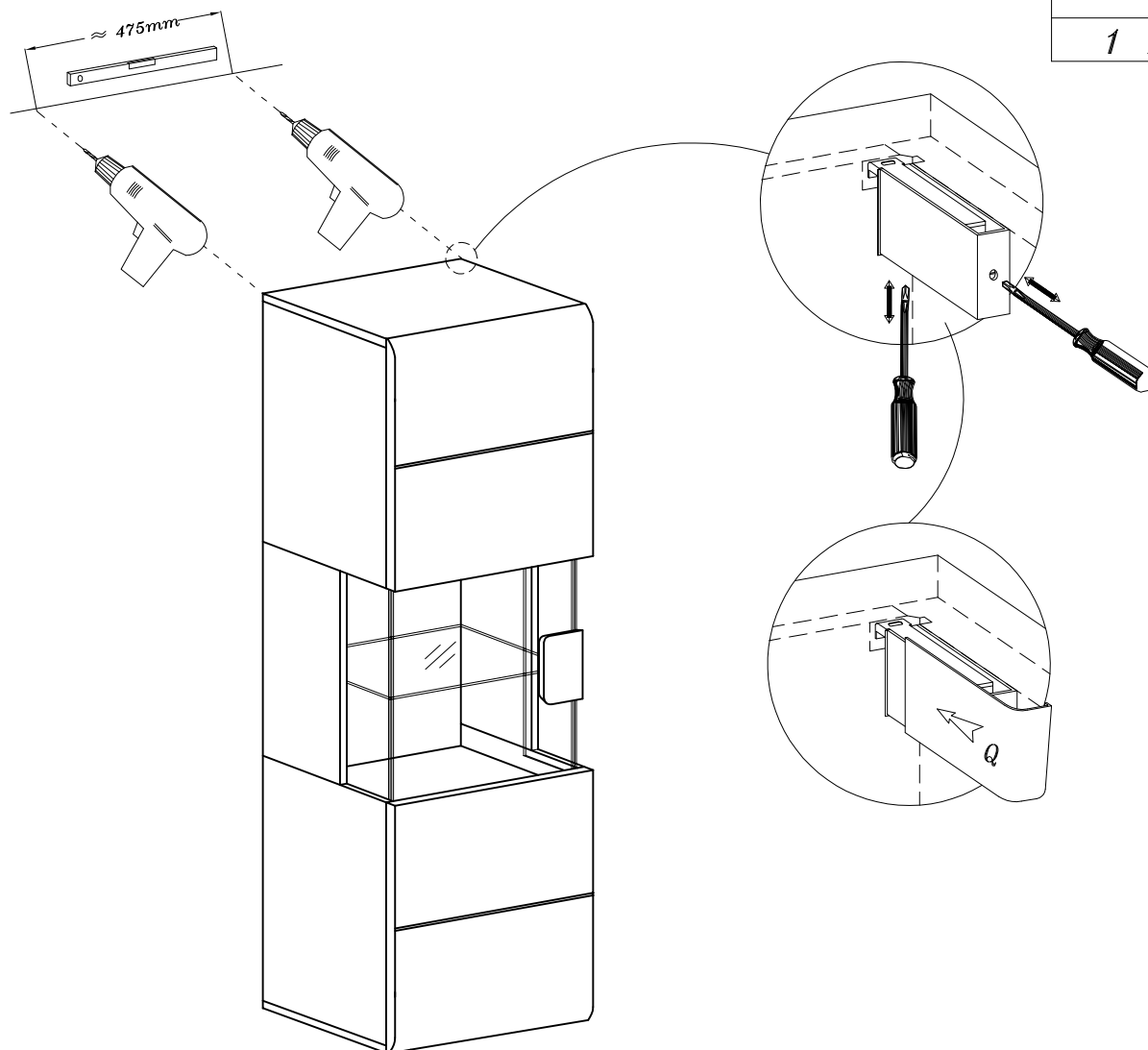

⚠ Uwaga • Upozornini • Achtung • Attention • Caution • Figyelem ⚠
⚠ Attenzione • Opgelet • Внимание • Atentie • Upozornenie • Dikkat ⚠

PL	Mocowanie mebla do ściany może przeprowadzić wyłącznie odpowiedni do tego personel, ponieważ w czasie montażu w ścianie konieczne jest zastosowanie dopasowanych kółków.
CZ	Připevnění nábytku ke stěně může uskutečnit výhradně k tomu určený personál, protože pro montáž je nutné použít hmoždinky shodné s typem a tloušťkou stěny.
D	Die Befestigung des Möbelstückes an der Wand muss von einer fachkundigen Person vorgenommen werden, da für die Montage an die Wand angepasste Dübel erforderlich sind.
GB	A qualified professional is required when mounting furniture to the wall since dowels corresponding to the wall are required for this.
F	Le montage du meuble au mur peut être fait uniquement par le personnel spécialisé. Il est nécessaire d'utiliser des chevilles bien ajustées pendant le montage au mur.
HU	A bútor a falhoz való rögzítését kizárólag erre illeltek személyzet végezheti, mivel a falhoz való rögzítés során megfelelő méretű csapszeg alkalmazása szükséges.
I	Attaccare un mobile alla parete può essere effettuato esclusivamente dal personale adatto perche' durante il montaggio bisogna usare dei cavicchi adatti.
NL	een vakkundige persoon dient het meubelstuk aan de muur te bevestigen; voor de montage aan de muur zijn immers aangepaste pluugen vereist.
RU	Поскольку для монтажа на стене необходимо использовать специальные дюбели, мебель должна быть закреплена на стене квалифицированным персоналом.
RO	Montarea mobilei pe perete poate fi efectuată numai de către personalul calificat deoarece la această montare se folosește cepuri.
SK	Připevnění nábytku k stěně může uskutečnit výhradně k tomu určený personál, protože k montáži je nutné použít hmoždinky vhodné s typem stěny a její hrúbkou.
TR	Möbilya parçasının duvara sabitlenmesi, duvar montajı için özel uyarlanmış dübeller gerektirdiğinden bu iş sadece bu konuda uzman bir kişi tarafından gerçekleştirilmelidir.

- (PL)** Uwaga: Punkty mocowania opcjonalnego oświetlenia
- (CZ)** Upozornění: body k připevnění doplňkového osvětlení
- (D)** Hinweis: Befestigungspunkte für optionale Beleuchtung
- (GB)** N.B.: Fixing points for optional lighting
- (F)** Remarque: Points de fixation de l'éclairage optionnel
- (HU)** Figyelem: Opcionális világítás rögzítési pontjai
- (I)** NOTA: punti di fissaggio opzionale dell'illuminazione
- (NL)** OPGELET: Optionele bevestigingspunten van de verlichting.
- (RU)** ВНИМАНИЕ: Точки крепления дополнительного освещения
- (RO)** Atenție: Punctele opționale de fixare a iluminatului
- (SK)** Upozornenie: body k pripevnení dodatočného osvetlení
- (TR)** Dikkat: Seçenekli aydınlatmanın yerleştirilmesinin noktaları

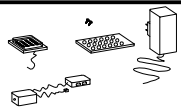

1 KPL

