

WARIS

MCA

furniture

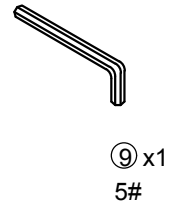
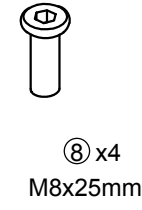
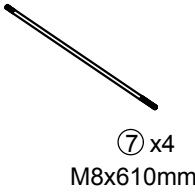
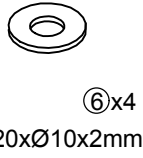
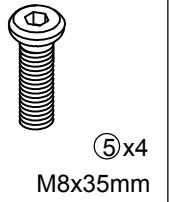
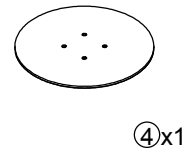
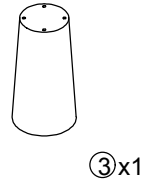
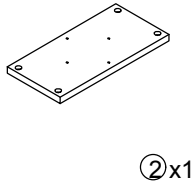
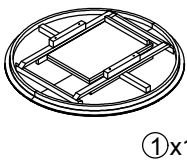
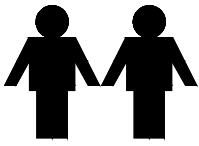

1

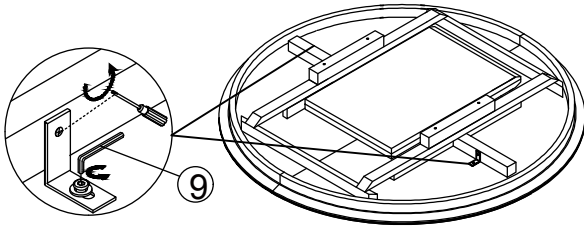

2

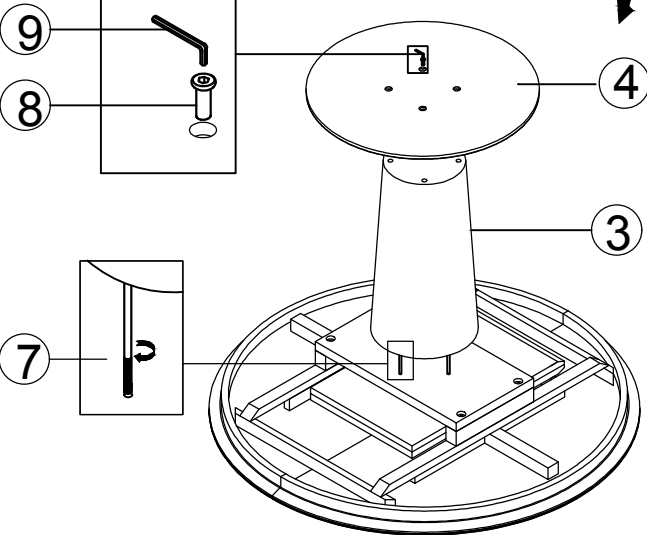
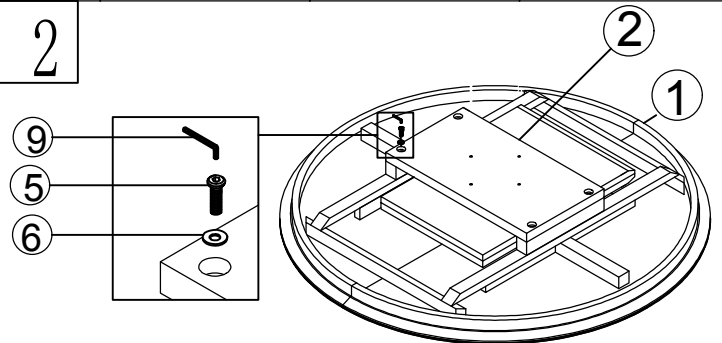

3

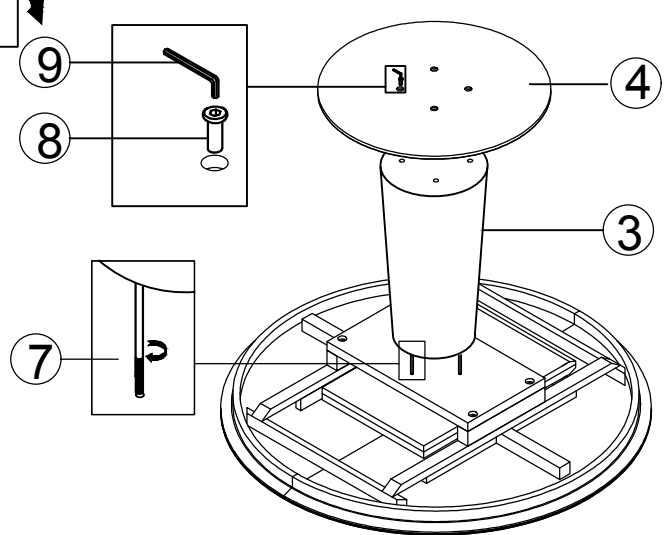

4

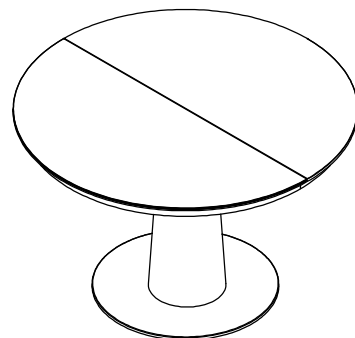
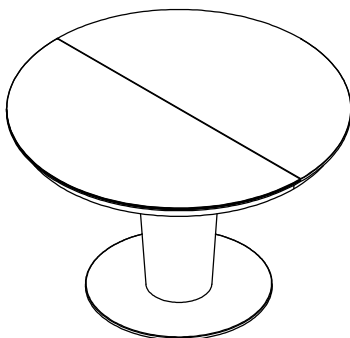

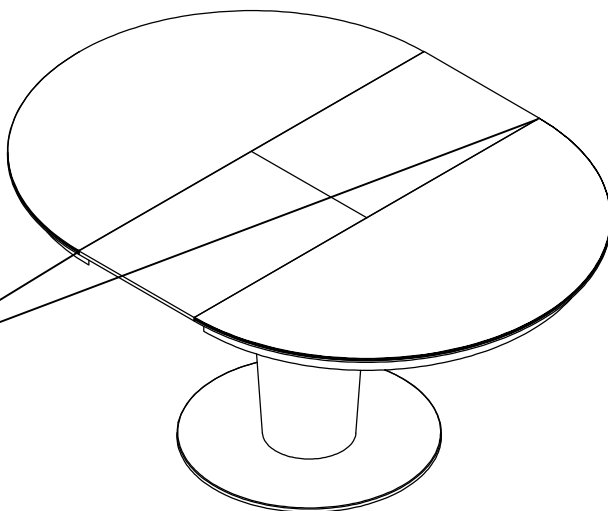
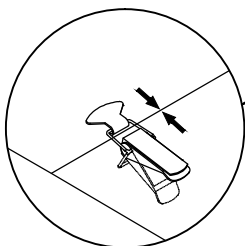
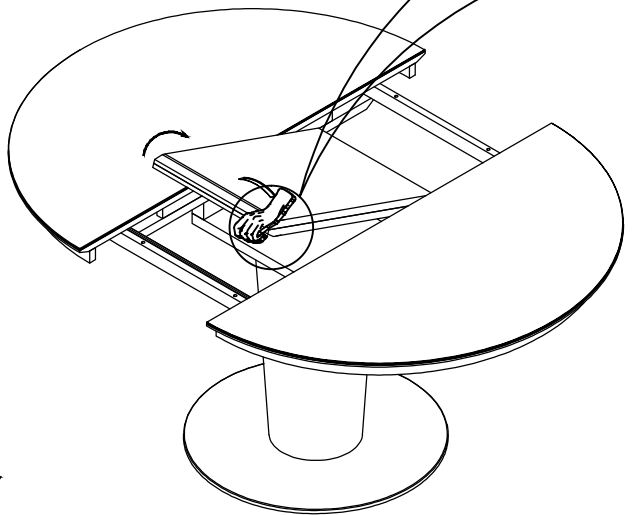
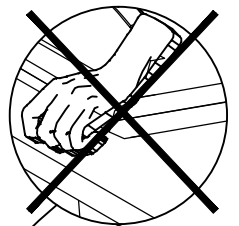
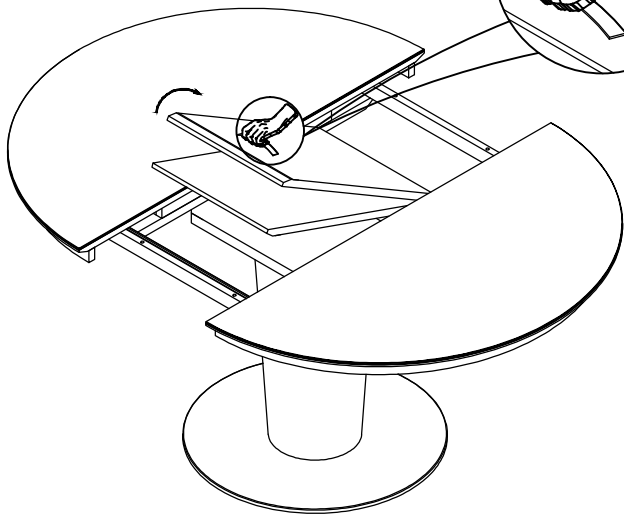
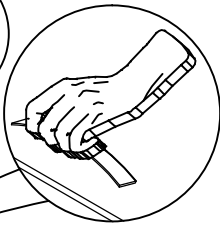
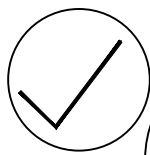
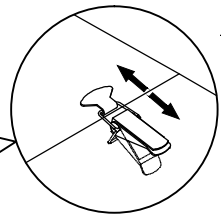
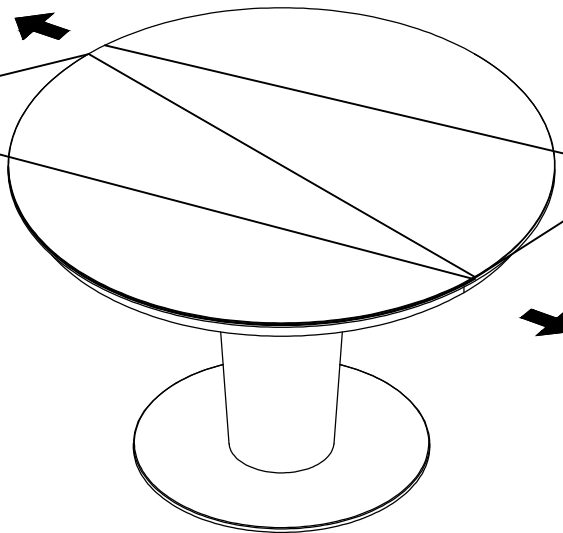
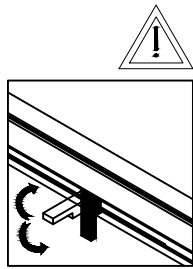

MCA

furniture

D	<p>Pflegehinweis: Die Glasplatte bitte nur mit einem Staubtuch oder feuchten Lappen reinigen und keine scheuernden Reiniger verwenden!</p>	DA	<p>Plejehenvisning: Glaspladen må kun rengøres med en støvklud eller en fugtig klud, og der må ikke anvendes skurende rengøringsmidler!</p>
EN	<p>Care instruction: Please use a duster or damp cloth to clean the glass tabletop and avoid any abrasive cleaners!</p>	ES	<p>Consejos de mantenimiento: Limpie la placa de vidrio con un trapo para el polvo o un paño húmedo sin utilizar en ningún momento productos abrasivos.</p>
FR	<p>Conseil d'entretien : Nettoyer le dessus de table en verre uniquement à l'aide d'un chiffon à poussière ou un chiffon humide et ne pas utiliser de nettoyeur abrasif !</p>	HR	<p>Napomenazaodržavanje: Staklenupločuočistitesamokrpozaprašniuilivlažnomkrpom i nemojtekoristitiabrazivnasredstvazačišćenje!</p>
NL	<p>Reinigingsinstructie: De glasplaat alleen met een stofdoek of vochtige doek reinigen en geen schurende schoonmaakmiddelen gebruiken!</p>	PL	<p>Wskazówka dotycząca pielęgnacji: Płytkę szklaną należy wycierać wyłącznie ścierką do kurzu lub wilgotną szmatką i nie stosować żadnych szorujących środków czyszczących!</p>
SK	<p>Pokyn na údržbu: Sklenenú dosku čistite iba prachovkou alebo vlhkou utierkou, nepoužívajte abrazívne čistiace prostriedky!</p>	SL	<p>Napotek za nego: Stekleno ploščo čistite le s krpo za prah ali vlažno krpo, ne uporabljajte grobih čistilnih sredstev.</p>
SV	<p>Skötselinformation: Rengör glasplattan endast med en dammtrasa eller fuktig lapp och använd inga skurande rengöringsmedel!</p>	IT	<p>Consigli di manutenzione: per la pulizia del piano di vetro utilizzare esclusivamente un panno per spolverare o uno straccio umido. Non usare detergenti abrasivi.</p>