



BISSELL Homecare, Inc.

P.O. Box 1888, Grand Rapids, MI 49501-1888, USA

2345 Walker Avenue NW, Grand Rapids, MI 49544-2516, USA

LITHIUM CELLS OR BATTERIES TEST SUMMARY IN ACCORDANCE WITH SUB-SECTION 38.3 OF UN MANUAL OF TESTS AND CRITERIA

Revision Date: 25 February 2022

Revision Number: 013

Product Manufacturer: **BISSELL International Trading Company B.V.**
Postbus 12874, 1100 AW Amsterdam Zuidoost, The Netherlands

Telephone: 011 (31) 20 305 1340 Amsterdam
800-237-7691 US/Canada
1300 BISSELL (247735) Australia

Email: support.BISSELL.com

Web: www.BISSELL.com

BISSELL product lithium ion cells and batteries have been successfully tested and comply with the UN Model Regulations, Manual of Test and Criteria, Part III, subsection 38.3.

| PERFORMED TESTS | | RESULTS |
|-----------------|------------------------|---------|
| 38.3.4.1 T1 | Altitude Simulation | Pass |
| 38.3.4.2 T2 | Thermal Test | Pass |
| 38.3.4.3 T3 | Vibration | Pass |
| 38.3.4.4 T4 | Shock | Pass |
| 38.3.4.5 T5 | External Short Circuit | Pass |
| 38.3.4.6 T6 | Impact / Crush | Pass |
| 38.3.4.7 T7 | Overcharge | Pass |
| 38.3.4.8 T8 | Forced Discharge | Pass |

The UN38.3 tests were performed by one of the following test houses and were tested to UN Manual Test and Criteria.

| | |
|--------------------------------------------------------------------------------------------------------------------------------------------------------------------------------------------------------------------------------------------------------------------------------------------------------------------------------------------------------------------------------------------------------|------------------------------------------------------------------------------------------------------------------------------------------------------------------------------------------------------------------------------------------------------------------------------------------------------------------------------------------------------------------------------------------------------------------------------|
| <p>Vkan Certification & Testing Co., Ltd. No. 3, Tianaiyi Road, Kaitai Avenue Science City, Guangzhou China E: office@cvc.org.cn T: 020 32293888 U: www.cvc.org.cn</p> | <p>Dongguan CTL Electromagnetic Technology Co., Ltd. Room 107, No. 2, Block 1, Area 1 Headquarters Road No. 2, Songshanhu Hi-tech Development Zone, Dongguan, Guangdong China E: richard.chen@dgctl-lab.com T: (0769) 22893710 U: www.dgctl-lab.com</p> |
| <p>Attestation of Global Compliance 2F., No. 2 Building, Huafeng No. 1 Technical Industrial Park, Sanwei, Xixiang, Baoan District, Shenzhen China E: agc@agc-cert.com T: (86-755) 29081955 U: www.agc-cert.com</p> | <p>Shenzhen Sem. Test Technology Co., Ltd. 1/FI, Room 101, Building 1, Hongwei Industrial Park, Liuxian'er Road, Block 70 Bao'an District, Shenzhen, Guangdong, China E: admin@semtest.com.cn T: +86-0755-33663308 U: www.semtest.com.cn</p> |
| <p>Shanghai Research Institute of Chemical Industry Testing Centre Reception Hall, Testing Center, West entrance, 345 East Yunling Road, Shanghai 200062 E: msds123@gmail.com T: 021-52802587 U: www.ghs.cn</p> | <p>Shenzhen STS Test Services Co., Ltd. 1/F., Building B, Zhuoke Science Park, No. 190 Chongging Road, Fuyong Street, Bao'an District, Shenzhen, Guangdong, China E: sts@stsapp.com T: +86-755 3688 6288 U: www.stsapp.com</p> |
| <p>Guangzhou MCM Certification and Testing Co., Ltd 1F No. 13, Zhong San Section, ShiGuang Road Panyu District, Guangzhou City, Guangdong Province, China E: markmiao@mcmtek.com T: 0086-20-3477 7662 U: www.mcmtek.com</p> | <p>Shenzhen Alpha Product Testing Co., Ltd. Building I, No. 2, Lixin Road, Fuyong Street Bao'an District, 518103 Shenzhen, Guangdong, China E: e011@a-lab.cn T: 4008-3008-95 U: www.a-lab.cn</p> |
| <p>UL-CCIC Company Limited Guangzhou Branch Electronic Building, Parage Electronic Industrial Park No. 8 Nanyun Er Road Guangzhou Science Park, Guangzhou, China E: customerservice.cn@cn.ul.com T: +86-20-3213 1000 U: www.ul.com</p> | <p>Shenzhen NTEK Testing Technology Co., Ltd. 1/F, Building C, Fenda Science Park, Sanwei Community, Xixiang Street, Bao'an District, 518126, Shenzhen, China E: Coco@ntek.org.cn T: +86-755-6115 6588 U: www.ntek.org.cn</p> |

Product Test Information

Model “(+)” means blank or letter or number with no functional difference.

Multi-cell rechargeable lithium ion batteries < 100Wh

| Model Numbers | Physical Description | Battery Weight (kg) Mass | Watt Hour (Wh) Rating | Test Report Number | Test Report Date | UN38.3 Edition |
|----------------------------------------------------------|----------------------------------------------------------------------------------------------------------------------------------------------------------------------------------------------------|--------------------------|-----------------------|--------------------|------------------|----------------|
| 3180+, 3181+, 3182+, 3183+ | Pet Stain Eraser OPP P3000 Battery 12X3.5X7cm Black plastic cement shell  | 0.140kg | 14.4 | 1120120316 | 2021-01-12 | Rev.6 A1 |
| | | 0.140kg | 14.4 | 1121050475 | 2021-06-18 | Rev.6 A1 |
| 1626647 S20R Battery | P3000 7.2V Li-ion Battery Pack 12X3.5X7 Black plastic cement shell  | 0.140kg | 14.4 | 1120120316 | 2021-01-12 | Rev.6 A1 |
| 1628158 CBAK2.0 Battery | P3000 7.2V Li-ion Battery Pack 12X3.5X7 Black plastic cement shell  | 0.140kg | 14.4 | 1121050475 | 2021-06-18 | Rev.6 A1 |
| 2837+, 2842+, 2846+, 2877+, 2982+, 2991+, 2992+ | Pet Stain Eraser 2.0 Cleaner P2953 Unit 41X20X12 cm Battery 5X5X10 cm White Irregular Shape  | 0.115kg | 18 | RZUN2020-0738 | 2020-04-16 | Rev.6 A1 |
| | | 0.170kg | 18 | RZUN2021-1137 | 2021-04-30 | Rev.7 |
| | | 0.172kg | 18 | RZUN2021-1136 | 2021-04-30 | Rev.7 |

Product Test Information

Model “(+)” means blank or letter or number with no functional difference.





Multi-cell rechargeable lithium ion batteries < 100Wh

| Model Numbers | Physical Description | Battery Weight (kg) Mass | Watt Hour (Wh) Rating | Test Report Number | Test Report Date | UN38.3 Edition |
|----------------------------|---------------------------------------------------------------------------------------------------------------------------------------------------------------------------------------|--------------------------|-----------------------|--------------------|------------------|----------------|
| 3050+ S25R Battery | P2953 7.2V Li-ion Battery Pack 5X5X10cm White Irregular Shape  | 0.115kg | 18 | RZUN2020-0738 | 2020-04-16 | Rev.6 A1 |
| 1627560 S25R8 Battery | P2953 7.2V Li-ion Battery Pack 5X5X10cm White Irregular Shape  | 0.170kg | 18 | RZUN2021-1137 | 2021-04-30 | Rev.7 |
| 1627394 VTC5 Battery | P2953 7.2V Li-ion Battery Pack 5X5X10cm White Irregular Shape  | 0.172kg | 18 | RZUN2021-1136 | 2021-04-30 | Rev.7 |
| 1629037 CBAK Battery | P2953 7.2V Li-ion Battery Pack 5X5X10cm White Irregular Shape  | 0.179kg | 18 | RZUN2021-3985 | 2021-12-20 | Rev.7 |
| 2002+, 2003+, 2005+, 2054+ | Pet Stain Eraser Cleaner P437-B1 Unit 41X20X12 cm Battery 8X4X4.5 cm (Black plastic enclosure)  | 0.147kg | 15.12 | RZUN2016-5040 | 2017-01-16 | Rev.6 |

Product Test Information

Model “(+)” means blank or letter or number with no functional difference.

Multi-cell rechargeable lithium ion batteries < 100Wh

| Model Numbers | Physical Description | Battery Weight (kg) Mass | Watt Hour (Wh) Rating | Test Report Number | Test Report Date | UN38.3 Edition |
|-----------------------------------|----------------------------------------------------------------------------------------------------------------------------------------------------------------------------------------------|--------------------------|-----------------------|--------------------|------------------|----------------|
| 2006+, 2164+ | Pet Stain Eraser Cleaner P437-B2 Unit 41X20X12 cm Battery 8X4X4.5 cm (White plastic enclosure)  | 0.240kg | 30.24 | RZUN2016-5041 | 2017-01-16 | Rev.6 |
| 1954+, 2133+, 2162+, 1959+, 2045+ | Bolt Vacuum P481-14 Unit 114 cm height Battery 14X4X2cm Black rectangular shape  | 0.194kg | 30.96 | A001B20170808054 | 2017-08-21 | Rev.6 |
| 89-0075-500-401 Battery | P481 14.4V Battery Pack 14X4X2 cm Black rectangular shape  | 0.194kg | 30.96 | A001B20170808054 | 2017-08-21 | Rev.6 |
| 1971+, 2023+ | Multireach Vacuum P481-25 Unit 114 cm height Battery 20X6X4cm Black Irregular shape  | 0.330kg | 54.2 | A001B20170502019 | 2017-06-07 | Rev.6 |

Product Test Information

Model “(+)” means blank or letter or number with no functional difference.





Multi-cell rechargeable lithium ion batteries < 100Wh

| Model Numbers | Physical Description | Battery Weight (kg) Mass | Watt Hour (Wh) Rating | Test Report Number | Test Report Date | UN38.3 Edition |
|----------------------------|--------------------------------------------------------------------------------------------------------------------------------------------------------------|--------------------------|-----------------------|--------------------|------------------|----------------|
| 61-0075-502 Battery | P481 25.2V Battery Pack 20X6X4 cm Black Irregular shape  | 0.330kg | 54.2 | A001B20170502019 | 2017-06-07 | Rev.6 |
| 2291+, 2294+, 2581+ | ICONpet Robot Vacuum P488 Unit 34X11 cm Battery 10X3X2cm Blue Prismatic  | 0.5467kg | 86.4 | RZUN2018-2647 | 2018-09-17 | Rev.6 |
| 2753 Battery, 2758 Battery | P488 18V Battery Pack 10X3x2cm Blue Prismatic  | 0.5467kg | 86.4 | RZUN2018-2647 | 2018-09-17 | Rev.6 |
| 3175+, 3177+, 3178+, 3281+ | ICON Pet Vacuum P3025 Unit 114cm Battery 6.5X3X1.8cm Prismatic White  | 0.426kg | 75.6 | RZUN2020-3609 | 2020-11-19 | Rev.6 A1 |

Product Test Information

Model “(+)” means blank or letter or number with no functional difference.

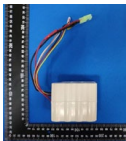
Multi-cell rechargeable lithium ion batteries < 100Wh

| Model Numbers | Physical Description | Battery Weight (kg) Mass | Watt Hour (Wh) Rating | Test Report Number | Test Report Date | UN38.3 Edition |
|-------------------------------------------------------|---------------------------------------------------------------------------------------------------------------------------------------------------------------------------------------------|--------------------------|-----------------------|--------------------|------------------|----------------|
| 1626397 S30Q Battery | P3025 25.2V Battery Pack 6.5X3X1.8cm Prismatic White  | 0.426kg | 75.6 | RZUN2020-3609 | 2020-11-19 | Rev.6 A1 |
| 2288+, 2774+, 2289+, 2899+, 1622228 Service Assembly | ICON Pet Vacuum P2822-21 P2961-21 Unit 114 cm height Battery 9X3X2 cm Prismatic White  | 0.375kg | 65 | RZUN2018-2637-M1 | 2019-01-04 | Rev.6 |
| | | 0.375kg | 65 | RZUN2018-2638-M2 | 2020-08-18 | Rev.6 |
| 1618212 Battery, 1620773 Battery, 61-0088-010 Battery | Battery Pack P2822-21 ICON Pet Battery 9X3X2 cm Prismatic White  | 0.375kg | 65 | RZUN2018-2637-M1 | 2019-01-04 | Rev.6 |
| | | 0.375kg | 65 | RZUN2018-2638-M2 | 2020-08-18 | Rev.6 |
| 2602+, 2746+, 2894+, 2953+, 2962+, 1621618 | ICON Pet Vacuum Li-ion Battery P2822-25 P2961-25 Unit 114 cm height Battery 9X3X2 cm Prismatic White  | 0.420kg | 75.6 | RZUN2018-2639-M1 | 2019-01-04 | Rev.6 |
| | | 0.420kg | 75.6 | RZUN2018-2640-M2 | 2020-08-18 | Rev.6 |
| 1618213 Battery, 1621430 Battery | P2822 25.2V Battery Pack 9X3X2 cm Prismatic White  | 0.420kg | 75.6 | RZUN2018-2639-M1 | 2019-01-04 | Rev.6 |

Product Test Information

Model “(+)” means blank or letter or number with no functional difference.

Multi-cell rechargeable lithium ion batteries < 100Wh

| Model Numbers | Physical Description | Battery Weight (kg) Mass | Watt Hour (Wh) Rating | Test Report Number | Test Report Date | UN38.3 Edition |
|---------------------------------------------------|------------------------------------------------------------------------------------------------------------------------------------------------------------------------------------------|--------------------------|-----------------------|--------------------|------------------|----------------|
| 1624370 S30Q Battery, 61-0088-012 Battery | P2822 25.2V Battery Pack 9X3X2 cm Prismatic White  | 0.420kg | 75.6 | RZUN2018-2640-M2 | 2020-08-18 | Rev.6 |
| 1984+, 2144+, 2524+, 1047+, 2167+, 3046+, SC7100+ | AirRam Vacuum P429 P2862 Unit 114 cm height Battery 10X8X8 cm Black plastic cement shell  | 0.452kg | 48.4 | XD20211202U01 | 2021-01-20 | Rev.7 |
| 1610319 Battery, 3006+ Battery, 1630224 Battery | AirRam MK2 Battery Assembly P429 P2862 Battery 10X8X8 cm Black plastic cement shell  | 0.452kg | 48.4 | XD20211202U01 | 2021-01-20 | Rev.7 |
| 1985+, 2168+, 2169+, 2151+ | Multi Hand Vacuum Li-ion Battery P2862 Unit 37X26X10 cm Battery 14X8.5X5 cm Black Irregular shape  | 0.406kg | 44 | STRD1607045S | 2016-07-05 | Rev.6 |
| 1610329, 1615991, 1612573 Battery | Multi MK2 P2862 22V Battery 14X8.5X5cm Black Irregular shape  | 0.406kg | 44 | STRD1607045S | 2016-07-05 | Rev.6 |

Product Test Information

Model “(+)” means blank or letter or number with no functional difference.



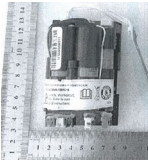
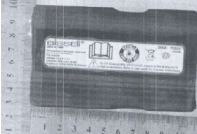

Multi-cell rechargeable lithium ion batteries < 100Wh

| Model Numbers | Physical Description | Battery Weight (kg) Mass | Watt Hour (Wh) Rating | Test Report Number | Test Report Date | UN38.3 Edition |
|-------------------------------|------------------------------------------------------------------------------------------------------------------------------------------------------------------------------------------------|--------------------------|-----------------------|--------------------|------------------|----------------|
| 2307+, 2315+, 2240+, 2309+ | SpinWave Cordless P2915 Unit 114 cm height Battery 10X7X5 cm Black/White plastic cement shell  | 0.278kg | 36 | 1117120273 | 2018-01-23 | Rev.6 A1 |
| | | 0.278kg | 39 | 1117110271 | 2018-01-23 | Rev.6 |
| | | 0.301kg | 36 | 1121030814 | 2021-04-29 | Rev.6 A1 |
| 2915. 18 S20R Battery | P2915 18.25V Battery Pack 10X7X5 cm Black/White plastic cement shell  | 0.278kg | 36 | 1117120273 | 2018-01-23 | Rev.6 A1 |
| 2915. 18.25 LG Battery | P2915 18.25V Battery Pack 10X7X5 cm Black/White plastic cement shell  | 0.278kg | 39 | 1117110271 | 2018-01-23 | Rev.6 |
| 1627244 CBAK2.0 Battery | P2915 18V Battery Pack 10X7X5 cm Black plastic cement shell  | 0.301kg | 36 | 1121030814 | 2021-04-29 | Rev.6 A1 |
| 1629193 LiShen Battery | P2915 18V Battery Pack 10X7X5 cm Black plastic cement shell  | 0.294kg | 36 | 1121100030 | 2021-11-08 | Rev.7 |

Product Test Information

Model “(+)” means blank or letter or number with no functional difference.



Multi-cell rechargeable lithium ion batteries < 100Wh

| Model Numbers | Physical Description | Battery Weight (kg) Mass | Watt Hour (Wh) Rating | Test Report Number | Test Report Date | UN38.3 Edition |
|--------------------------------------------------------------------------------------------------------------------|------------------------------------------------------------------------------------------------------------------------------------------------------------------------------------------------------------|--------------------------|-----------------------|----------------------|------------------|----------------|
| 2554+, 2595+, 2597+, 2590+, 2596+, 2593+, 2765+, 2767+, 2858+, 2854+, 2855+, 2857+, 2582+, 2588+ | CrossWave Cordless Max P2921 Unit 114cm Battery Pack 20X7X5 cm White/Blue Irregular shape  | 0.640kg | 90 | RZUN2019-0059- M2 | 2019-01- 28 | Rev.6 |
| | | 0.629kg | 90 | RZUN2021-1977 | 2021-04- 28 | Rev.7 |
| | | 0.638kg | 90 | RZUN2021-1870 | 2021-05- 07 | Rev.6 |
| 1625756 S25R Battery | P2921 36V Battery Pack 20X7X5 cm Black Irregular shape  | 0.640kg | 90 | RZUN2019-0059- M2 | 2020-04- 07 | Rev.6 |
| 1627561 S25R8 Battery | P2921 36V Battery Pack 36X6X5 cm White/Blue Irregular shape  | 0.629kg | 90 | RZUN2021-1977 | 2021-04- 28 | Rev.7 |
| 1626919 VTC5 Battery | P2921 36V Battery Pack 36X6X5 cm White/Blue Irregular shape  | 0.638kg | 90 | RZUN2021-1870 | 2021-05- 07 | Rev.7 |
| 2482+, 2286+ | PowerLifter Adapt Ion Vacuum P2922-10 Unit 114 cm height Battery 7X6X2 cm Black plastic cement shell  | 0.208kg | 21.6 | 1118030241 | 2018-05- 08 | Rev.6 |

Product Test Information

Model “(+)” means blank or letter or number with no functional difference.

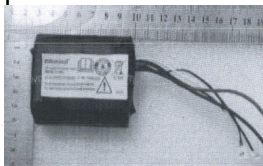
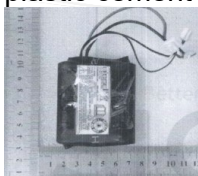
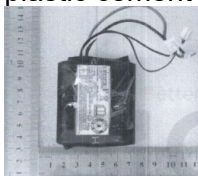

Multi-cell rechargeable lithium ion batteries < 100Wh

| Model Numbers | Physical Description | Battery Weight (kg) Mass | Watt Hour (Wh) Rating | Test Report Number | Test Report Date | UN38.3 Edition |
|--------------------------|---------------------------------------------------------------------------------------------------------------------------------------------------------------------------------------------|--------------------------|-----------------------|--------------------|------------------|----------------|
| P2922. 10.8 S20R Battery | P2922 10.8V Battery Pack 7X6X2 cm Black plastic cement shell  | 0.210kg | 21.6 | 1118030241 | 2018-05-08 | Rev.6 |
| 3061+, 3190+, 3191+ | PowerLifter Adapt Ion Vacuum P2922-10A Unit 114 cm height Battery 7X6X2 cm Black plastic cement shell  | 0.208kg | 27 | 1120060525 | 2020-08-13 | Rev.6 A1 |
| | | 0.155kg | 27 | 1121040127 | 2021-05-07 | Rev.6 A1 |
| | | 0.163kg | 27 | 1121040132 | 2021-05-11 | Rev.6 A1 |
| P2922. 10.8 S25R Battery | P2922 10.8V Battery Pack 7X6X2 cm Black plastic cement shell  | 0.160 | 27 | 1120060525 | 2020-08-13 | Rev.6 A1 |
| 1627640 S25R8 Battery | P2922 10.8V Battery Pack 7X6X2 cm Black plastic cement shell  | 0.155kg | 27 | 1121040127 | 2021-05-07 | Rev.6 A1 |
| 1627238 CBAK2.5 Battery | P2922 10.8V Battery Pack 7X6X2 cm Black plastic cement shell  | 0.163kg | 27 | 1121040132 | 2021-05-11 | Rev.6 A1 |

Product Test Information

Model “(+)” means blank or letter or number with no functional difference.

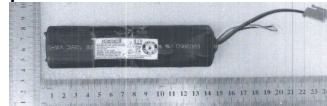
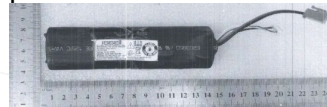



Multi-cell rechargeable lithium ion batteries < 100Wh

| Model Numbers | Physical Description | Battery Weight (kg) Mass | Watt Hour (Wh) Rating | Test Report Number | Test Report Date | UN38.3 Edition |
|-------------------------------------------------|-------------------------------------------------------------------------------------------------------------------------------------------------------------------------------------------------------------|--------------------------|-----------------------|--------------------|------------------|----------------|
| 2275+, 3034+, 3079+, 2387+, 2390+, 2284+, 2278+ | Pet Hair Eraser Adapt Ion XRT Vacuum P2922/2923-14 Unit 114cm Battery 15X5X4 cm Black plastic cement shell  | 0.195kg | 28.8 | 117120310 | 2018-01-26 | Rev.6 |
| | | 0.200kg | 28.8 | 1121040188 | 2021-05-17 | Rev.6 A1 |
| P2922. 14.4 S20R Battery | P2922 14.4V Battery Pack 15X5X4 cm Black plastic cement shell  | 0.195kg | 28.8 | 117120310 | 2018-01-26 | Rev.6 |
| 1627654 CBAK2.0 Battery | P2923 14.4V Battery Pack 15X5X4 cm Black plastic cement shell  | 0.200kg | 28.8 | 1121040188 | 2021-05-17 | Rev.6 A1 |
| 3192+, 3079+ | Pet Hair Eraser Adapt Ion XRT Vacuum P2922-14A Unit 114 cm height Battery 15X5X4 cm Black plastic cement shell  | 0.207kg | 36 | 1120060524 | 2020-07-27 | Rev.6 A1 |
| | | 0.198kg | 36 | 1121040129 | 2021-05-07 | Rev.6 A1 |
| | | 0.211kg | 36 | 1121040133 | 2021-05-11 | Rev.6 A1 |

Product Test Information

Model “(+)” means blank or letter or number with no functional difference.

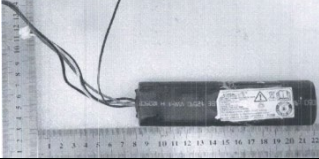



Multi-cell rechargeable lithium ion batteries < 100Wh

| Model Numbers | Physical Description | Battery Weight (kg) Mass | Watt Hour (Wh) Rating | Test Report Number | Test Report Date | UN38.3 Edition |
|--------------------------|---------------------------------------------------------------------------------------------------------------------------------------------------------------------------------------|--------------------------|-----------------------|--------------------|------------------|----------------|
| P2922. 14.4 S25R Battery | P2922 14.4V Battery Pack 15X5X4 cm Black plastic cement shell  | 0.207kg | 36 | 1120060524 | 2020-07-27 | Rev.6 A1 |
| 1627642 S25R8 Battery | P2922 14.4V Battery Pack 15X5X4 cm Black plastic cement shell  | 0.198kg | 36 | 1121040129 | 2021-05-07 | Rev.6 A1 |
| 1627239 CBAK2.5 Battery | P2922 14.4V Battery Pack 15X5X4 cm Black plastic cement shell  | 0.211kg | 36 | 1121040133 | 2021-05-11 | Rev.6 A1 |
| 2279+ | Multireach Essential Vacuum P2922-18 Unit 114 cm height Battery 15X5X4 cm Black plastic shell  | 0.308kg | 36 | 1118030240 | 2018-03-21 | Rev.6 |
| 2280+ | Multireach Essential Vacuum P2922-18 Unit 114 cm height Battery 15X5X4 cm Black plastic cement  | 0.308kg | 36 | 1118030240 | 2018-05-11 | Rev.6 |

Product Test Information

Model “(+)” means blank or letter or number with no functional difference.

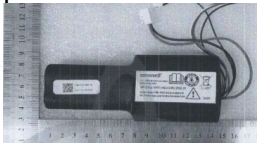



Multi-cell rechargeable lithium ion batteries < 100Wh

| Model Numbers | Physical Description | Battery Weight (kg) Mass | Watt Hour (Wh) Rating | Test Report Number | Test Report Date | UN38.3 Edition |
|-------------------------|-----------------------------------------------------------------------------------------------------------------------------------------------------------------------------------------------|--------------------------|-----------------------|--------------------|------------------|----------------|
| P2922.18V S20R Battery | P2922 18V Battery Pack 15X5X4 cm Black plastic cement shell  | 0.308kg | 36 | 1118030240 | 2018-05-11 | Rev.6 |
| 2280Z |  Multireach Essential Vacuum P2922-18 Unit 114 cm height Battery 15X5X4 cm Black plastic cement shell | 0.263kg | 45 | 1120060523 | 2020-07-27 | Rev.6 A1 |
| | | 0.252kg | 45 | 1121040130 | 2021-05-07 | Rev.6 A1 |
| | | 0.269kg | 45 | 1121040128 | 2021-05-07 | Rev.6 A1 |
| P2922.18V S25R Battery | P2922 18V Battery Pack 15X5X4 cm Black plastic cement shell  | 0.263kg | 45 | 1120060523 | 2020-07-27 | Rev.6 A1 |
| 1627644 S25R8 Battery | P2922 18V Battery Pack 15X5X4 cm Black plastic cement shell  | 0.252kg | 45 | 1121040130 | 2021-05-07 | Rev.6 A1 |
| 1627240 CBAK2.5 Battery | P2922 18V Battery Pack 15X5X4 cm Black plastic cement shell  | 0.269kg | 45 | 1121040128 | 2021-05-07 | Rev.6 A1 |

Product Test Information

Model “(+)” means blank or letter or number with no functional difference.





Multi-cell rechargeable lithium ion batteries < 100Wh

| Model Numbers | Physical Description | Battery Weight (kg) Mass | Watt Hour (Wh) Rating | Test Report Number | Test Report Date | UN38.3 Edition |
|----------------------------------------------------------|-----------------------------------------------------------------------------------------------------------------------------------------------------------------------------------------------|--------------------------|-----------------------|--------------------|------------------|----------------|
| 2907+, 2900+, 2903+, 2921+, 3274+, 3080+, 3111+ | Pet Hair Eraser Slim Vacuum P2983 Unit 114 cm height Battery 115 mm X 95 mm Black plastic shell  | 0.350kg | 54 | 1120040566 | 2020-06-18 | Rev.6 A1 |
| | | 0.343kg | | 1121030098 | 2021-04-02 | Rev.6 A1 |
| 1624302 S25R Battery | P2983 21.6V Battery Pack 115 mm X 95 mm Black plastic cement shell  | 0.350kg | 54 | 1120040566 | 2020-04-29 | Rev.6 A1 |
| 1627648 S25R8 Battery | P2983 21.6V Battery Pack 115 mm X 95 mm Black plastic cement shell  | 0.343kg | 54 | 1121030098 | 2021-04-02 | Rev.6 A1 |
| 1627646 CBAK2.5 Battery | P2983 21.6V Battery Pack 115 mm X 95 mm Black plastic cement shell  | 0.360kg | 54 | 1121060223 | 2021-07-26 | Rev.7 |
| 2389+ | Pet Hair Eraser Vacuum P2923-10 Unit 114 cm height Battery 7X6X2 cm Black plastic shell  | 0.167kg | 21.6 | 1118040025 | 2018-05-16 | Rev.6 |

Product Test Information

Model “(+)” means blank or letter or number with no functional difference.

Multi-cell rechargeable lithium ion batteries < 100Wh

| Model Numbers | Physical Description | Battery Weight (kg) Mass | Watt Hour (Wh) Rating | Test Report Number | Test Report Date | UN38.3 Edition |
|------------------------------------------|---------------------------------------------------------------------------------------------------------------------------------------------------------------------------------------------------|--------------------------|-----------------------|---------------------|------------------|----------------|
| 2279+ | MultiClean Hand Vacuum P2923-18 Unit 12 cm height Black plastic cement shell  | 0.276kg | 36 | 1118070008 | 2018-08-01 | Rev.6 |
| 2983+, 3018+ | MultiReach Ion XL Vacuum P2902A Unit 114 cm height Battery 21X10X6 cm Black Irregular Shape  | 0.504kg | 99 | AGC01497200301 UA01 | 2020-03-31 | Rev.6 A1 |
| | | 0.504kg | 99 | AGC01497200704 UA01 | 2020-08-15 | Rev.6 A1 |
| 1624923 Battery, 1624923 LM29 Battery | MultiReach Ion XL Vacuum P2902A Battery 21X10X6 cm Black Irregular Shape  | 0.504kg | 99 | AGC01497200301 UA01 | 2020-03-31 | Rev.6 A1 |
| | | 0.504kg | 99 | AGC01497200704 UA01 | 2020-08-15 | Rev.6 A1 |
| 2551+, 2582+, 2588+ | CrossWave Cordless Wet Dry Vacuum P2934 Unit 114 cm height Battery 20X7X5 cm Black plastic cement shell  | 0.651kg | 90 | RZUN2018-2682 | 2018-12-14 | Rev.6 |
| | | 0.634kg | | 1121040045 | 2021-05-12 | Rev.6 A1 |
| | | 0.642kg | | 1121030669 | 2021-05-12 | Rev.6 A1 |

Product Test Information

Model “(+)” means blank or letter or number with no functional difference.





Multi-cell rechargeable lithium ion batteries < 100Wh

| Model Numbers | Physical Description | Battery Weight (kg) Mass | Watt Hour (Wh) Rating | Test Report Number | Test Report Date | UN38.3 Edition |
|-----------------------------------------------------------------------------------------------------------------------------------------------------------------|--------------------------------------------------------------------------------------------------------------------------------------------------------------------------------------------------------|--------------------------|-----------------------|--------------------|------------------|----------------|
| 1618930 S25R Battery | P2934 36V Battery Pack 20X7X5 cm Black plastic cement shell  | 0.651kg | 90 | RZUN2018-2682 | 2018-12-14 | Rev.6 |
| 1627559 S25R8 Battery | P2934 36V Battery Pack 20X7X5 cm Black plastic cement shell  | 0.634kg | 90 | 1121040045 | 2021-05-12 | Rev.6 A1 |
| 1627558 VTC5 Battery | P2934 36V Battery Pack 20X7X5 cm Black plastic cement shell  | 0.642kg | 90 | 1121030669 | 2021-05-12 | Rev.6 A1 |
| 3011+, 3041+, 3055+, 3068+, 3073+, 3267+, 3276+, 3277+, 3279+, 3287+, 2832+, 2955+, 3592+, 3602+, 3559+, 3563+, 3564+, 3400+, 3401+, 3479+, 3597+, 3604+, 3608+ | CrossWave Cordless X7/X7+ Wet Dry Vacuum P2954/P3078 Unit 112 cm height Battery 20X7X5 cm Black Irregular shape  | 0.467kg | 75.6 | RZUN2020-1492 | 2020-07-24 | Rev.6 A1 |
| | | 0.463kg | 75.6 | RZUN2021-2034 | 2021-05-19 | Rev.7 |
| 1625227, 1624370, 1625384, 1625383, 1625382 30Q Battery | P2954 25.2V Battery Pack 10X9X5 cm Black Irregular shape  | 0.467kg | 75.6 | RZUN2020-1492 | 2020-07-24 | Rev.6 A1 |
| 1628025 VTC6 Battery | P2954 25.2V Battery Pack 10X9X5 cm Black Irregular shape  | 0.463kg | 75.6 | RZUN2021-2034 | 2021-05-19 | Rev.7 |

Product Test Information

Model “(+)” means blank or letter or number with no functional difference.

Multi-cell rechargeable lithium ion batteries < 100Wh

| Model Numbers | Physical Description | Battery Weight (kg) Mass | Watt Hour (Wh) Rating | Test Report Number | Test Report Date | UN38.3 Edition |
|---------------------------------------------------------------------------|------------------------------------------------------------------------------------------------------------------------------------------------------------------------------------------------------|--------------------------|-----------------------|--------------------|------------------|----------------|
| 3548+ | TurboClean Hard Floors Wet Dry Vacuum P3094 Unit 112 cm height Battery 20X7X5 cm Black Irregular shape  | 0.480kg | 57.7 | 1121110302 | 2021-12-27 | Rev.7 |
| FBP090 Battery | P3094 22.2V Battery Pack 10X9X5 cm Black Irregular shape  | 0.480kg | 57.7 | 1121110302 | 2021-12-27 | Rev.7 |
| 2601+, 2503+, 2908+, 2933+, 3110+ | Robot Vacuum P2949 – P3001 Unit 32X8 cm Battery 18.24X65.22mm Green and Prismatic  | 0.188kg | 36 | STS1801143B01 | 2018-01-18 | Rev.6 |
| | | 0.188kg | 36 | RZUN2021-1364 | 2021-07-09 | Rev.7 |
| 2859+, 3115+, 3347+, 2931+ | Robot Vacuum P3011 Unit 32X8 cm Battery 18.24X65.22mm Green and Prismatic  | 0.187kg | 36 | S20062803801001 | 2020-07-20 | Rev.6 A1 |
| | | 0.188kg | 36 | RZUN2021-1364 | 2021-07-09 | Rev.7 |
| 1618526 Battery, INR18650 M26-4S1P Battery, 1624434 Battery International | Battery Mid Tier P2949, P3001, P3011 14.4V Battery 7X4X4 cm Green and Prismatic  | 0.188kg | 36 | STS1801143B01 | 2018-01-18 | Rev.6 |
| | | 0.188kg | 36 | S20062803801001 | 2020-07-20 | Rev.6 A1 |

Product Test Information

Model “(+)” means blank or letter or number with no functional difference.





Multi-cell rechargeable lithium ion batteries < 100Wh

| Model Numbers | Physical Description | Battery Weight (kg) Mass | Watt Hour (Wh) Rating | Test Report Number | Test Report Date | UN38.3 Edition |
|------------------------------------------------------------|---------------------------------------------------------------------------------------------------------------------------------------------------------------------------------|--------------------------|-----------------------|------------------------|------------------|----------------|
| 1626913 Battery, 1626914 Battery International | SpinWave P3011 14.4V Battery 7X4X4 cm Blue and Prismatic  | 0.188kg | 36 | RZUN2021-1364 | 2021-07-09 | Rev.7 |
| 3377+, 3393+, 3552+, 3475+ | Robot Vacuum P3049 14.8V Unit 32x8 cm Battery 15x5x5 cm Blue and Prismatic  | 0.198kg | 44.4 | PN202105244837 501 | 2021-06-08 | Rev. 7 |
| N048-4S1P Battery | Battery P3049 14.8V 15x5x5 cm Blue and Prismatic  | 0.198kg | 44.4 | PN202105244837 501 | 2021-06-08 | Rev. 7 |
| 1974+, 2142+, 1927+, 2147+ | SmartClean Robot Vacuum P2950 Unit 32X8 cm Battery 13X4X2 cm Black Prismatic  | 0.190kg | 41.1 | GDCTL201711030 001A | 2018-01-17 | Rev.6 |
| 1616749 Battery | Battery 14.68V Li Ion P2950 SmartClean Robot Battery 13X4X2 cm Black Prismatic  | 0.190kg | 41.1 | GDCTL201711030 001A | 2018-01-17 | Rev.6 |

Product Test Information

Model “(+)” means blank or letter or number with no functional difference.

Multi-cell rechargeable lithium ion batteries < 100Wh

| Model Numbers | Physical Description | Battery Weight (kg) Mass | Watt Hour (Wh) Rating | Test Report Number | Test Report Date | UN38.3 Edition |
|-----------------------|-------------------------------------------------------------------------------------------------------------------------------------------------------------------------------------|--------------------------|-----------------------|--------------------|------------------|----------------|
| 3571+ | ReadyClean Robot Vacuum P3097 Battery 14.4V 7x4x4 cm Green and Prismatic  | 0.197kg | 36 | BYD20210425U01 | 2021-05-19 | Rev. 7 |
| D126-4S1P Battery | ReadyClean Robot P3097 Battery 14.4V 7x4x4 cm Green and Prismatic  | 0.197kg | 36 | BYD20210425U01 | 2021-05-19 | Rev. 7 |
| 2986+ | Aero Slim Hand Vacuum P3008 Unit 22X7 cm Battery 6.8X4X2.5 cm White irregular shape  | 0.110 kg | 7.2 | RZUN2019-2371 | 2019-08-19 | Rev.6 A1 |
| VC3936-3C-P-T Battery | P3008 7.2V Battery 6.8X4X2.5 cm White irregular shape  | 0.110 kg | 7.2 | RZUN2019-2371 | 2019-08-19 | Rev.6 A1 |

Product Test Information

Model “(+)” means blank or letter or number with no functional difference.



Multi-cell rechargeable lithium ion batteries < 100Wh

| Model Numbers | Physical Description | Battery Weight (kg) Mass | Watt Hour (Wh) Rating | Test Report Number | Test Report Date | UN38.3 Edition |
|------------------------------------|-----------------------------------------------------------------------------------------------------------------------------------------------------------------------|--------------------------|-----------------------|--------------------|------------------|----------------|
| VP200ESK, VP20A Battery | Victory Handheld Cordless Sprayer Unit 44X17X35 cm Black cuboid battery  | 0.285 kg | 48.96 | A1912225-C01-R11 | 2017-06-29 | Rev.6 |
| VP300ES, VP20A Battery | Victory Back Pack Cordless Sprayer Unit hand 22X17X35 cm Black cuboid battery  | 0.285 kg | 48.96 | A1912225-C01-R11 | 2017-06-29 | Rev.6 |
| VP20A Battery 3400 mAh 14.4V | Victory VP20A Battery Black cuboid battery  | 0.285 kg | 48.96 | A1912225-C01-R11 | 2017-06-29 | Rev.6 |
| VP20B Battery 6800 mAh 14.4V | Victory VP20B Battery Black cuboid battery  | 0.462 kg | 97.92 | A1912225-C01-R12 | 2017-06-29 | Rev.6 |

Product Test Information

Model “(+)” means blank or letter or number with no functional difference.

Multi-cell rechargeable lithium ion batteries > 100Wh

| Model Numbers | Physical Description | Battery Weight (kg) Mass | Watt Hour (Wh) Rating | Test Report Number | Test Report Date | UN38.3 Edition |
|------------------------------|--------------------------------------------------------------------------------------------------------------------------------------------------------------------------------------------|--------------------------|-----------------------|--------------------|------------------|----------------|
| 2166+ | MultiReach Ion XL Vacuum P2902 Unit 114 cm height Battery 21X10X6 cm Black Irregular Shape  | 0.519kg | 102.6 | A001B20170424065 | 2017-05-16 | Rev.6 |
| SC7500A | 7500 Series Com Upright Vacuum P2970 Unit 114 cm height Battery 30X10X5 cm Black Prismatic  | 0.875kg | 124.8 | PNS2106442604001 | 2021-06-23 | Rev.7 |
| 1630224 Battery, SC50B | P2970 43.2V Battery Pack 30X10X5 cm Black Prismatic  | 0.875kg | 124.8 | PNS2106442604001 | 2021-06-23 | Rev.7 |

Model “(+)” means blank or letter or number with no functional difference.

Primary Button Cell non-rechargeable lithium metal batteries

| Model Numbers | Physical Description | Battery Weight (kg) Mass | Watt Hour (Wh) Rating | Test Report Number | Test Report Date |
|---------------|----------------------|--------------------------|-----------------------|--------------------|------------------|
|---------------|----------------------|--------------------------|-----------------------|--------------------|------------------|

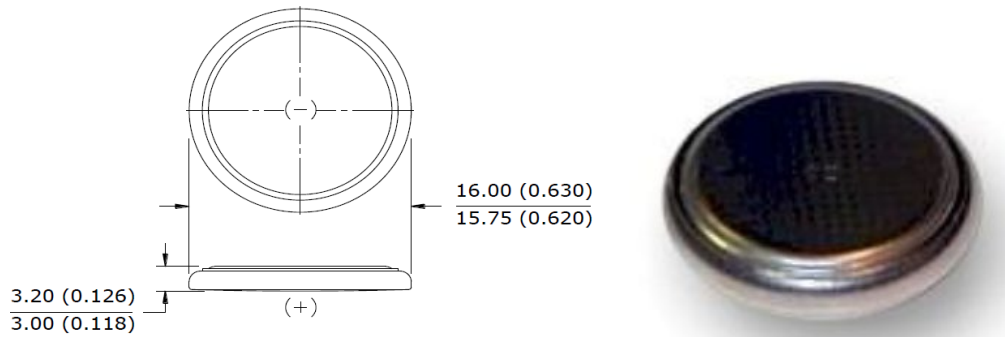

Industry Standard Dimensions

mm (inches)



Model “(+)” means blank or letter or number with no functional difference.

Primary Button Cell non-rechargeable lithium metal batteries

| Model Numbers | Physical Description | Battery Weight (kg) Mass | Watt Hour (Wh) Rating | Test Report Number | Test Report Date |
|-------------------------------------------------|---------------------------------------------------------------------------------------------------------------------------------------------------------------------------------------------------------------------------|--------------------------|-----------------------|--------------------|------------------|
| 1650+, 2087+, 2281+, 2461+, 1941+, 1900+, 1869+ | Pet Hair Eraser Vacuum, LED Crevice Tool Accessory P446 Unit 114 cm height Button cell batteries in tool Tool = 26X5X4 cm  | 0.002kg | NA | 1118070091 | 2018-08-23 |
| 1607896 Tool | Tool – Crevice Tool P466 26X5X4 cm  | 0.002kg | NA | 1118070091 | 2018-08-23 |

Model “(+)” means blank or letter or number with no functional difference.

Primary Button Cell non-rechargeable lithium metal batteries

| Model Numbers | Physical Description | Battery Weight (kg) Mass | Watt Hour (Wh) Rating | Test Report Number | Test Report Date |
|---------------|----------------------|--------------------------|-----------------------|--------------------|------------------|
|---------------|----------------------|--------------------------|-----------------------|--------------------|------------------|

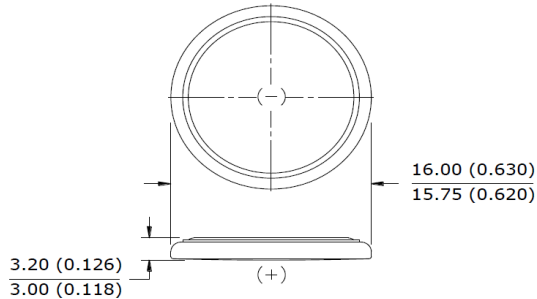

Industry Standard Dimensions

mm (inches)



Model “(+)” means blank or letter or number with no functional difference.

Primary Button Cell non-rechargeable lithium metal batteries

| Model Numbers | Physical Description | Battery Weight (kg) Mass | Watt Hour (Wh) Rating | Test Report Number | Test Report Date |
|---------------|-----------------------------------------------------------------------------------------------------------------------------------------------------------------------------------------------------------------------------|--------------------------|-----------------------|--------------------|------------------|
| 2513+ | Little Green ProHeat, LED Spray Crevice Tool Accessory P2907 Unit 39 cm height Button cell batteries in tool Tool 25X6X4 cm  | 0.002kg | NA | LJKJ20180901U08 | 2018-09-25 |
| 1614188 Tool | Tool-LED Spraying Crevice P2907 Tool 25X6X4 cm  | 0.002kg | NA | LJKJ20180901U08 | 2018-09-25 |

Name & Title of the authority:

Sebastian Asensio de Vries
VP - International Business Growth and Development

Signature:

Handwritten signature of Sebastian Asensio de Vries in blue ink.

Date:

February 28, 2022