

Mille 3023

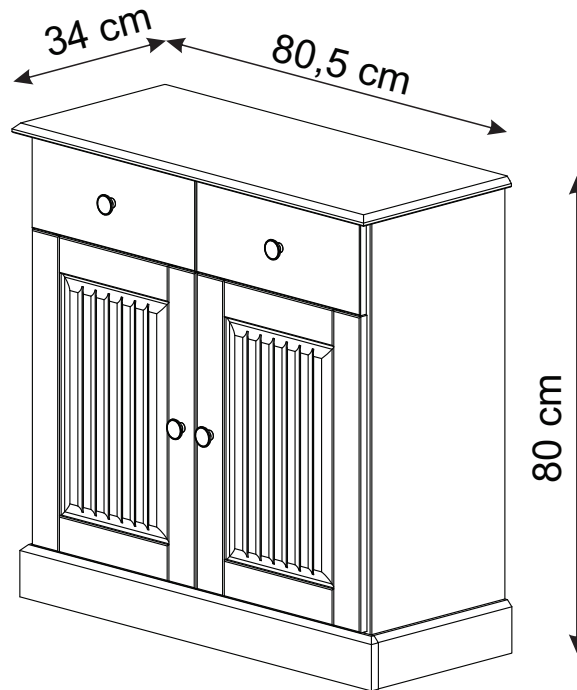

D Montageanleitung
3023

FR Notice de montage
3023

NL Handleiding voor de montage
3023

CZ Montážní návod
3023

HU Szerelési útmutató
3023

TR Montaj talimatı
3023

GB Assembly instructions
3023

IT Istruzioni di montaggio
3023

PL Instrukcja montażu
3023

SK Návod na montáž
3023

RO Instrucțiuni de montaj
3023



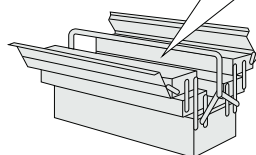
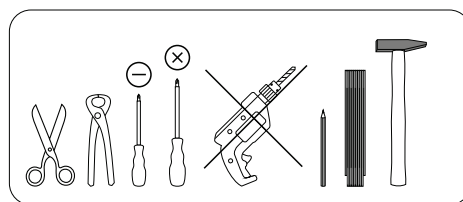
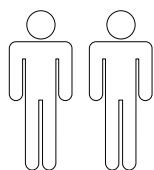



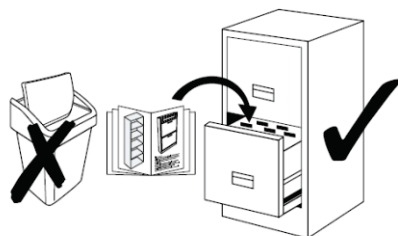
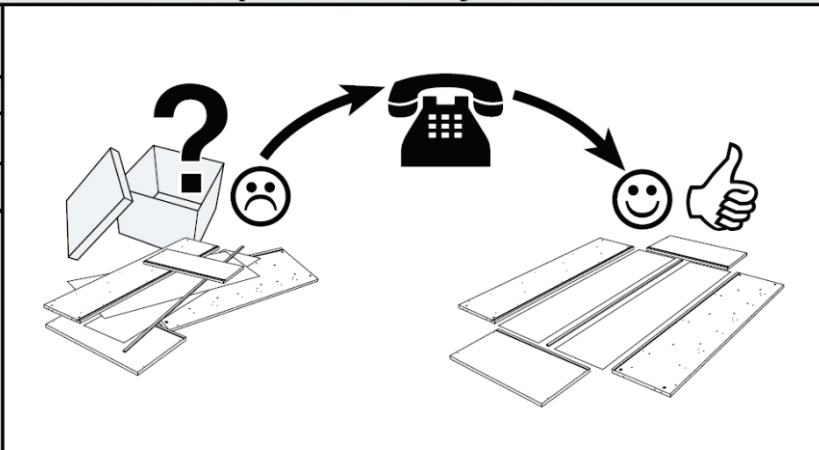

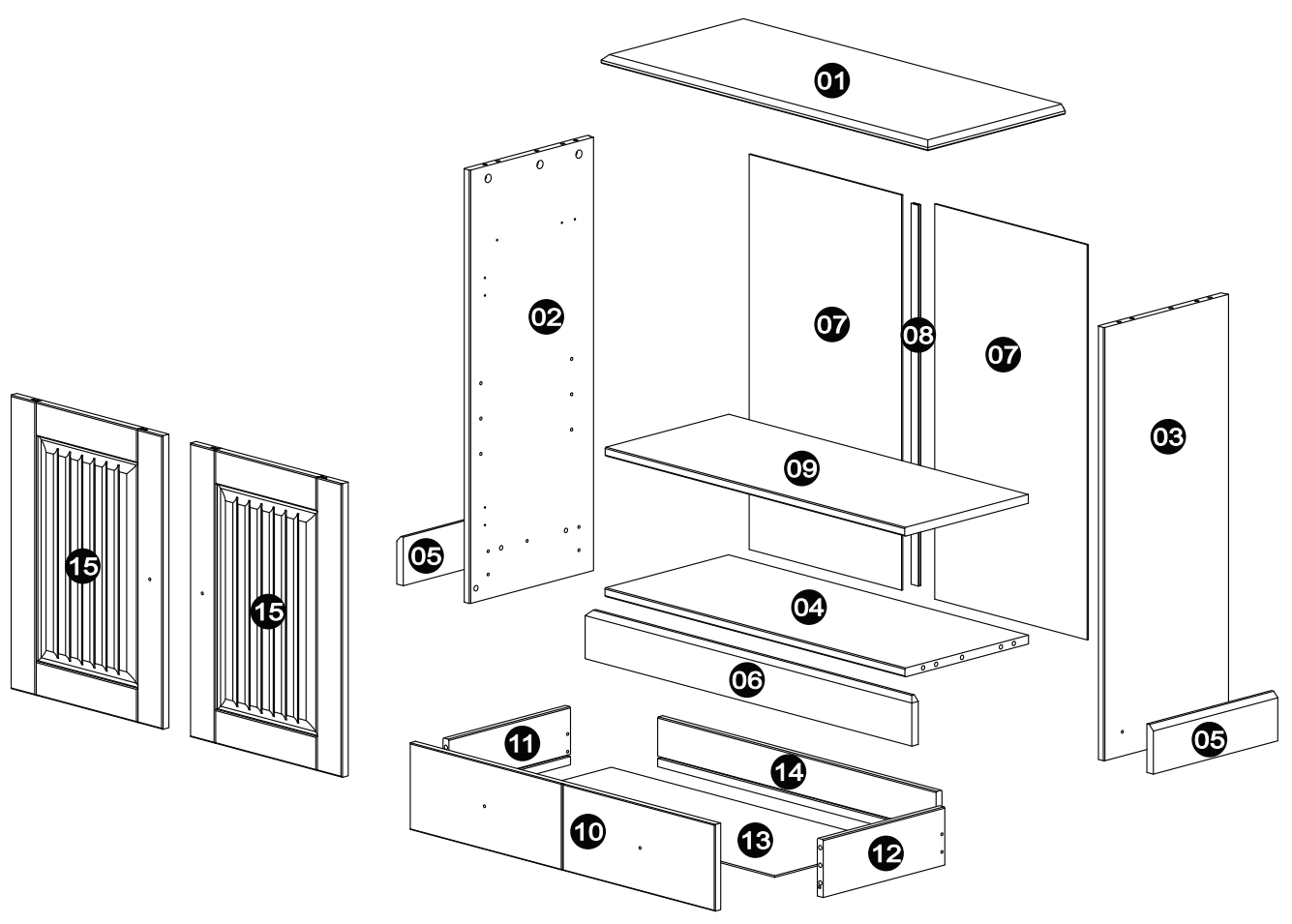







RU Инструкция по монтажу
3023



0
10
20
30
40
50
60
70
80
90
100
110
120
130
140
150
160
170
180
190
200

Service • Assistenza • Dienstverlening • Serwis Servis • Szerviz • Сервисная служба	
Name • Nom • Nome • Naam • Nazwa • Jméno • Názov • Név • Denumire • Isim • Название	
Nr. • No. • N° • Номер • Č • Sz	
Typ • Type • Tip • Típus • Tipo • Тип	
	
	



A 8,0x30  12x	B  14x	C  4x	D 3,5x14  28x	E 300  1x	F 300  1x	G  14x	H  5x	I  24x
J  2x	K 3,5x30  4x	L  4x	M 4,0x25  9x	N C7  4x	O M4x25  4x	P  1x	Q 4,5x60  1x	

1

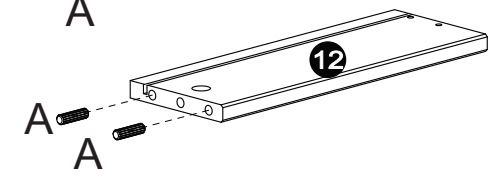
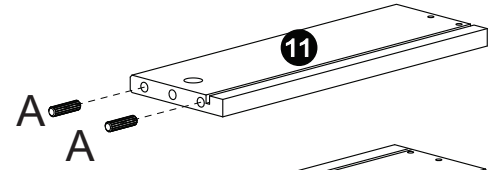
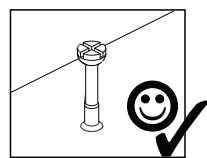
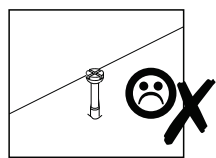
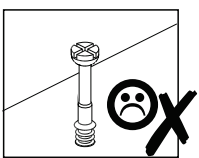
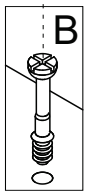
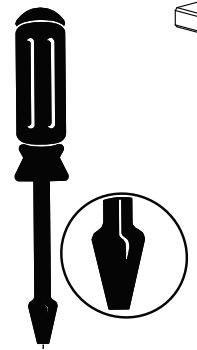
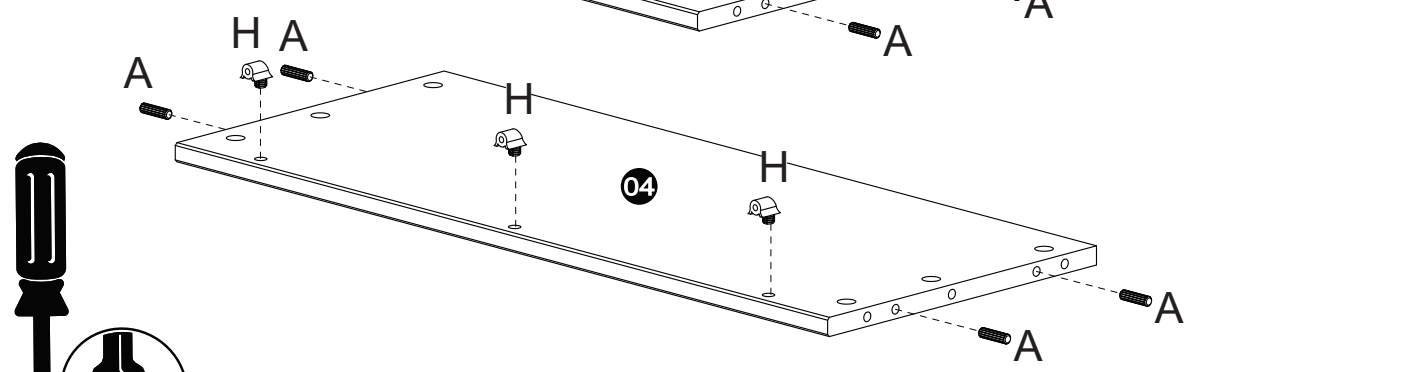
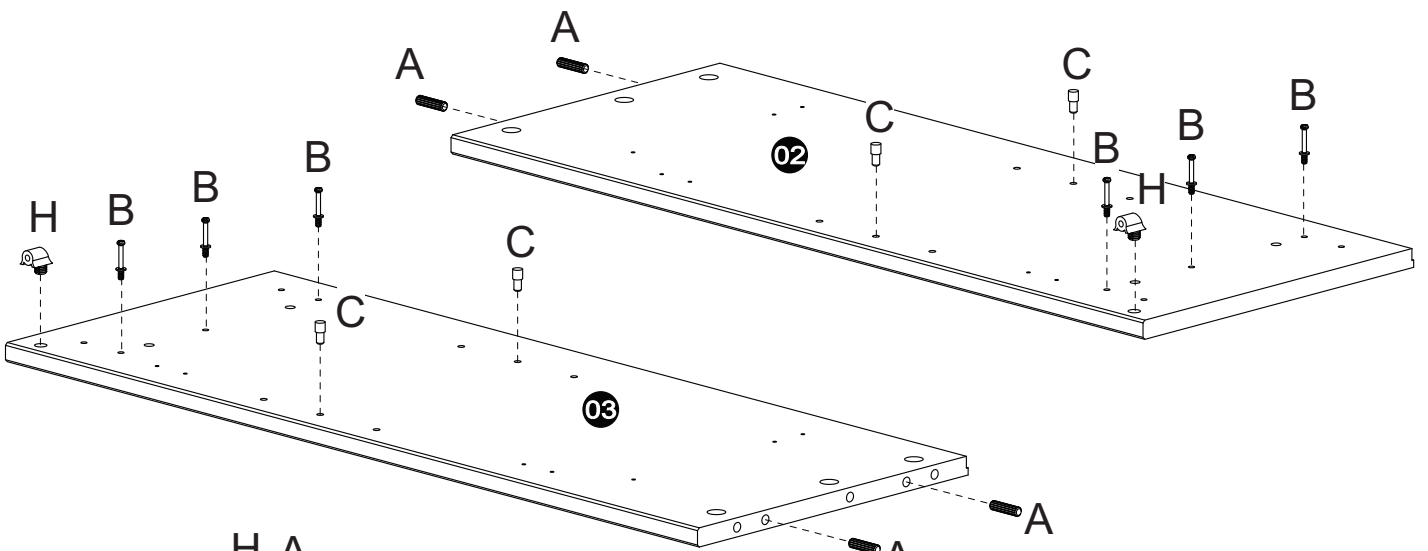
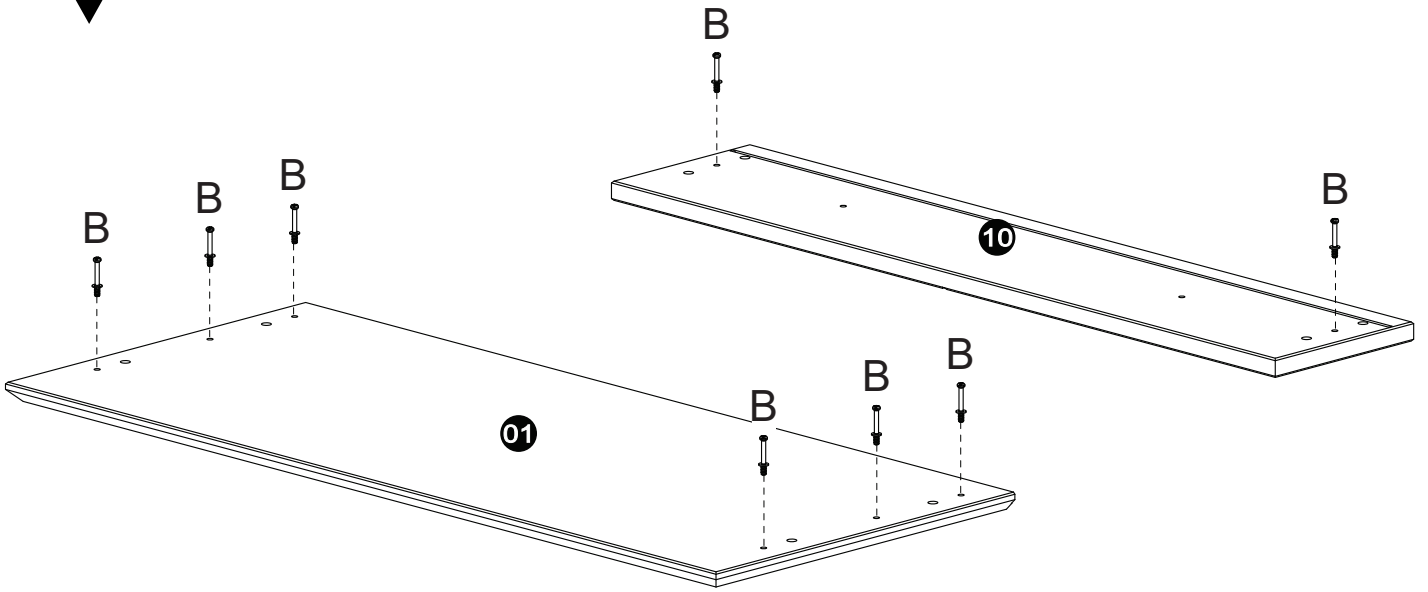
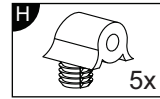
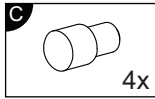
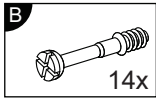
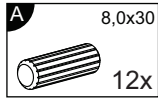

2

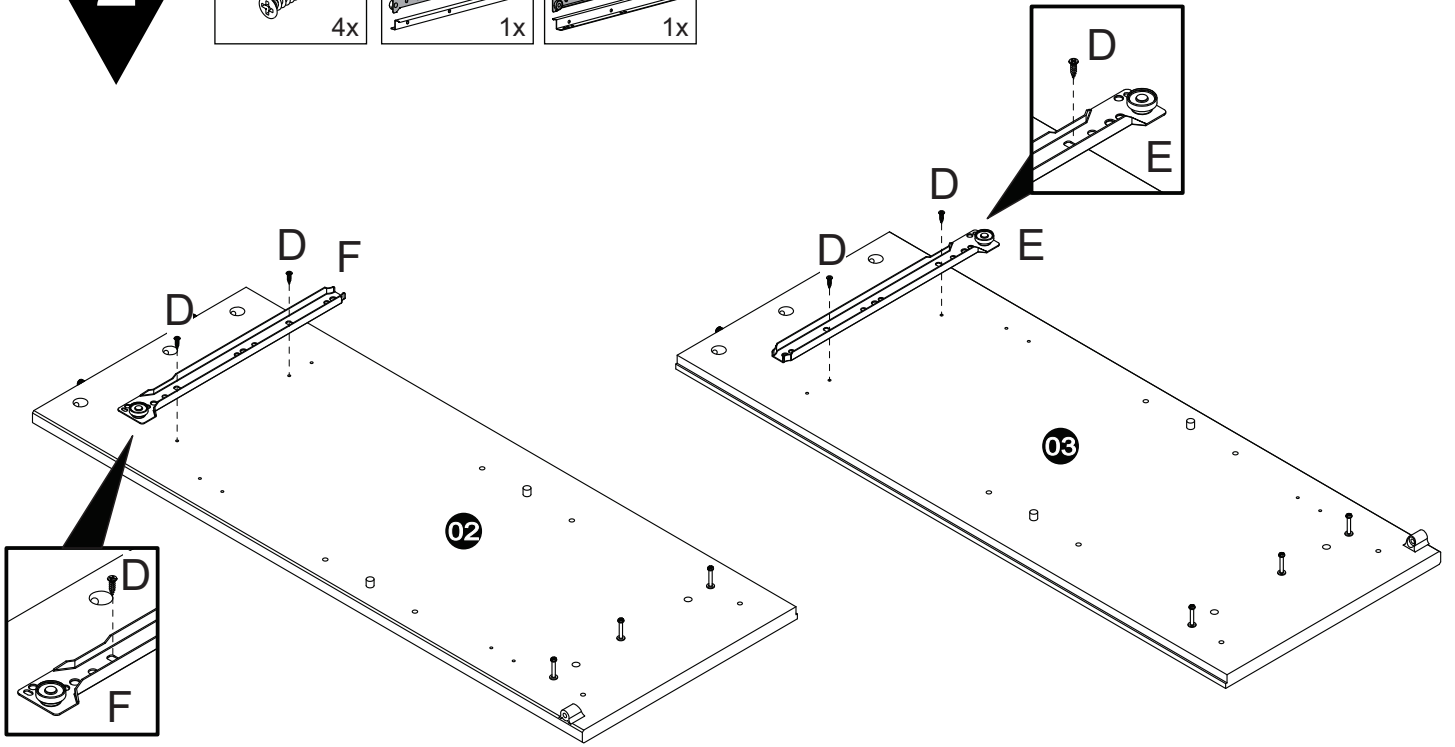
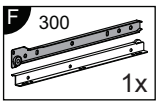
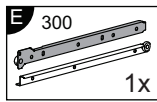
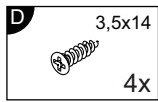

3

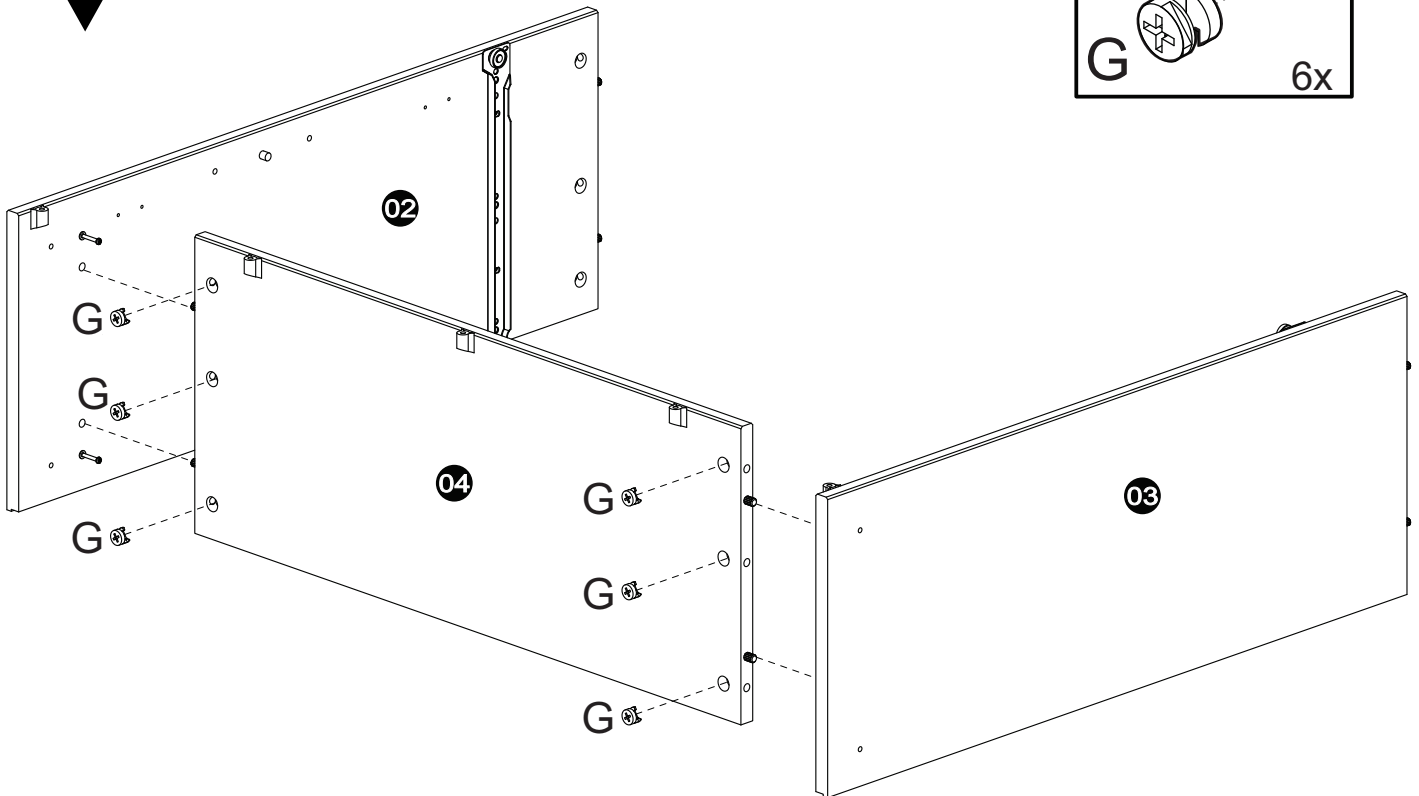
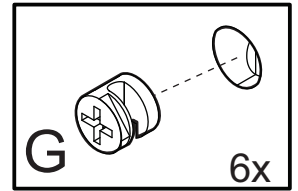
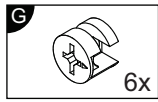

4

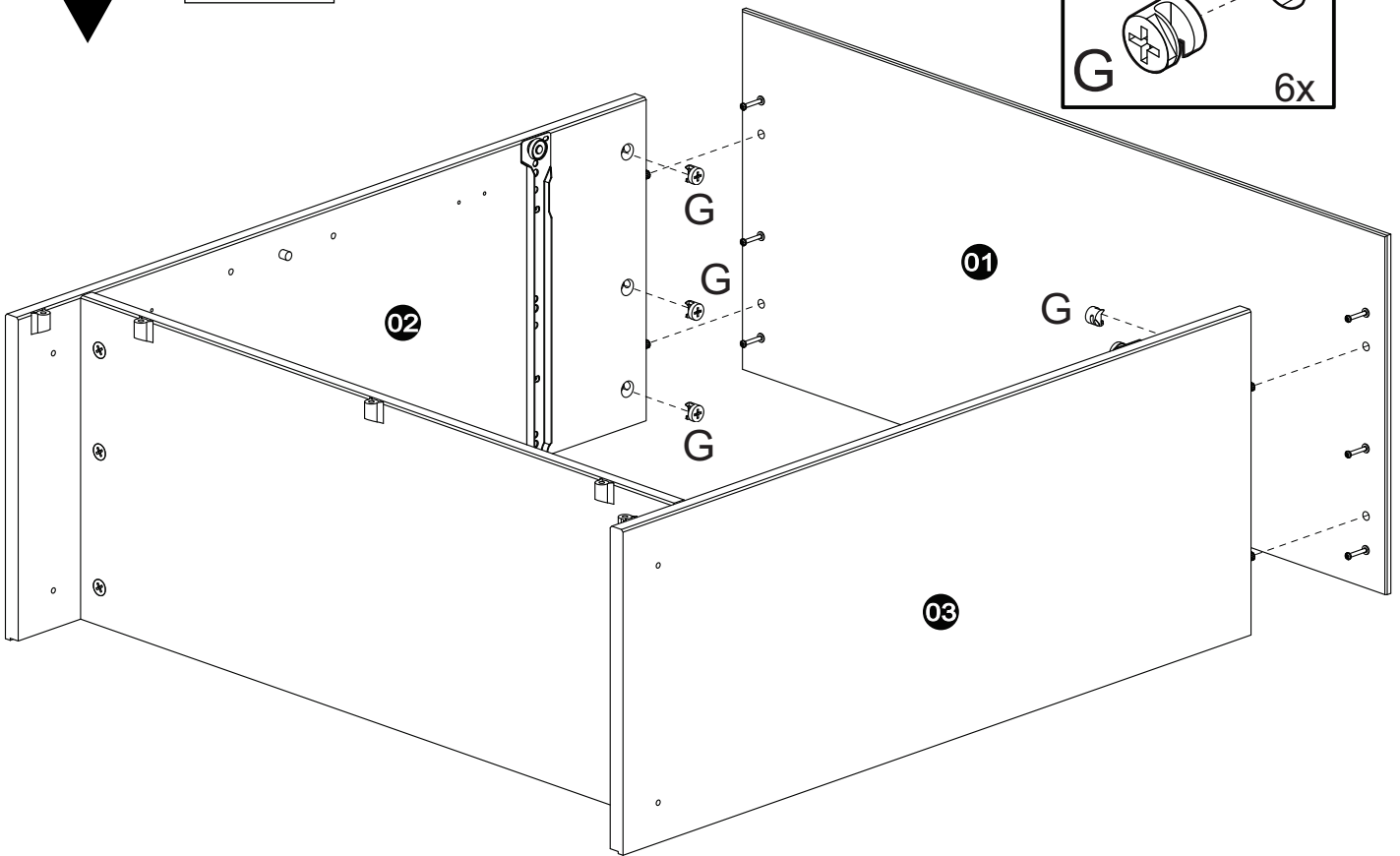
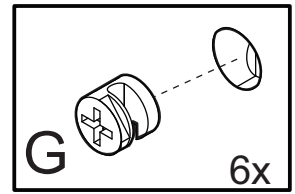
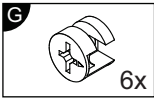

5

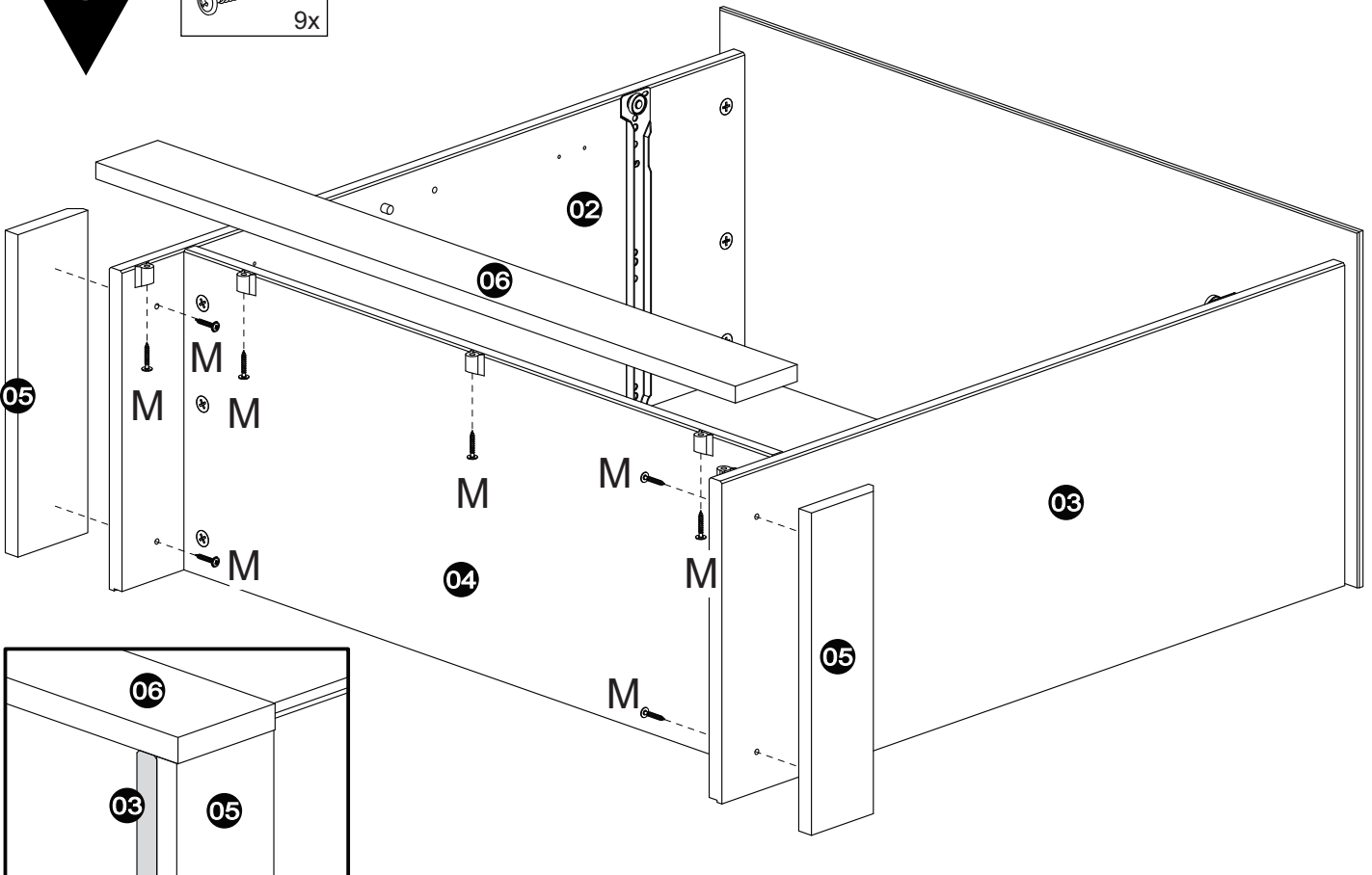
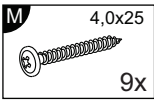

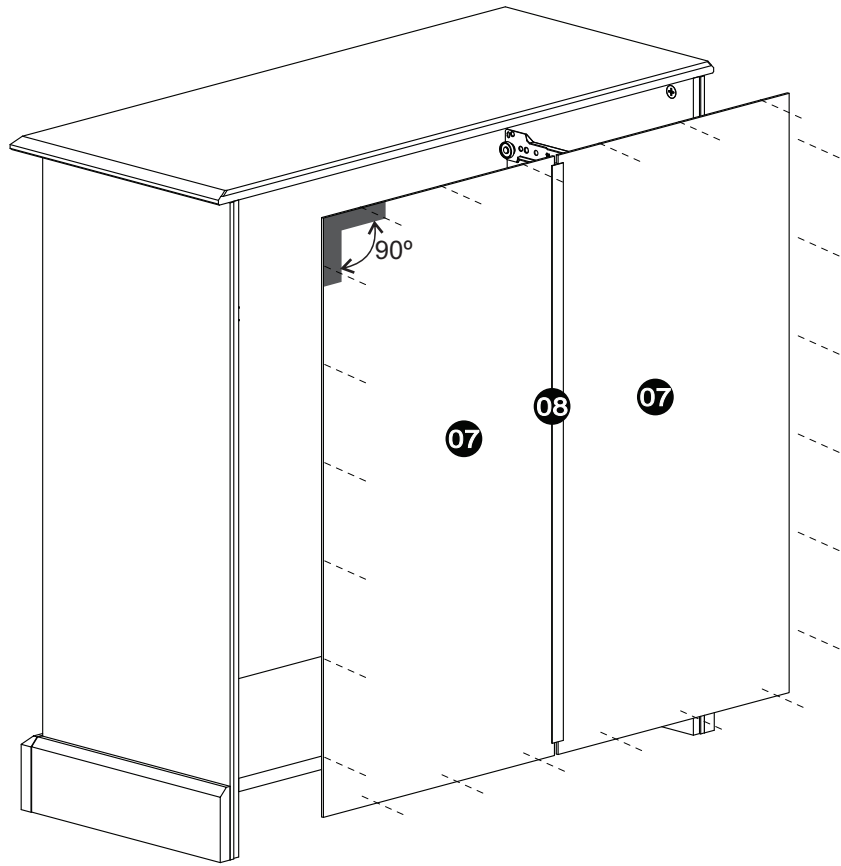
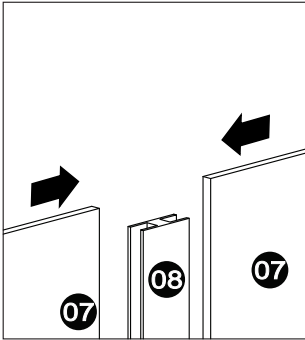
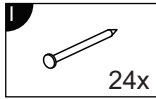

6

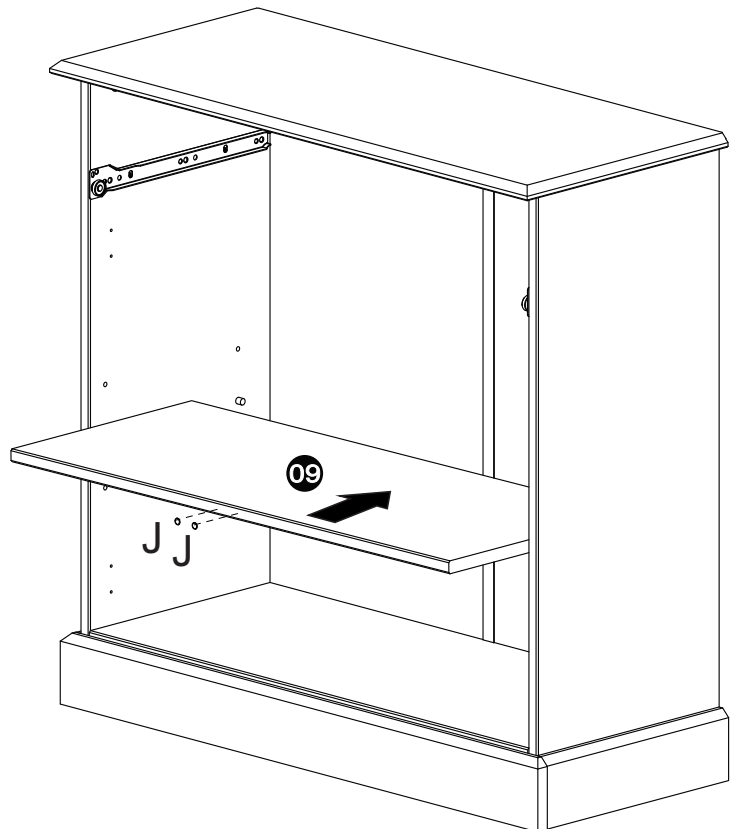
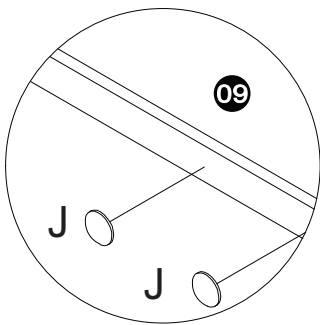
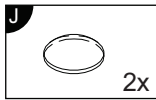

7

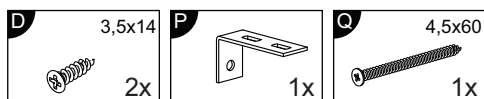



 Achtung • Attention • Attenzione Opgelet • Uwaga • Pozor • Figyelem Atenție • Dikkat • Внимание 	
(D)	Wandbefestigung dient als Kippschutz – unbedingt anbringen! Bei einigen Wandtypen kann ein Spezialdübel erforderlich sein!
(GB)	The wall fastening serves to prevent tipping – be absolutely sure to mount it! For certain wall types, a special wall plug may be necessary!
(FR)	La fixation murale sert de protection contre le basculement – à installer impérativement ! Pour certains types de murs il faut des chevilles spéciales !
(IT)	Il fissaggio alla parete serve da protezione anti-ribaltamento – attaccarla assolutamente! Per alcune strutture di parete può essere necessario un tassello speciale!
(NL)	Bevestiging aan de muur dient als kantelbescherming – zeker en vast bevestigen! Bij enkele muurtypes is een speciale plug misschien vereist!
(PL)	Mocowanie do ściany jest jednocześnie zabezpieczeniem przed przewróceniem – koniecznie zamontować! Do niektórych rodzajów ścian koniecznie zastosować specjalne kolki mocujące.
(CZ)	Montáž na stěnu slouží jako ochrana proti převrnutí – bezpodmínečně umístěte! U některých typů stěn může být zapotřebí speciální hmoždinka!
(SK)	Upevnenie na stenu slúži ako ochrana proti prevráteniu – bezpodmienečne použite! Pre niektoré druhy stien môže byť potrebná špeciálna hmoždinka!
(HU)	A termék a falhoz kel rögzíténi, különben az felborulhat! Egyes fal típusoknál speciális tiplit kell használni!
(RO)	Sistemul de fixare la perete servește ca protecție la răsturnare – de montat obligatoriu! Pentru unele tipuri de pereți este posibil să fie necesar un diblu special!
(TR)	Duvardaki sabitleme, devrilmeye karşı bir emniyet tedbiridir ve mutlaka monte edilmelidir! Bazı duvar tiplerinde bunun için özel bir dübel gerekli olabilir!
(RU)	Обязательно установите крепление на стене во избежание опрокидывания! Для некоторых типов стен может потребоваться специальный дюбель!

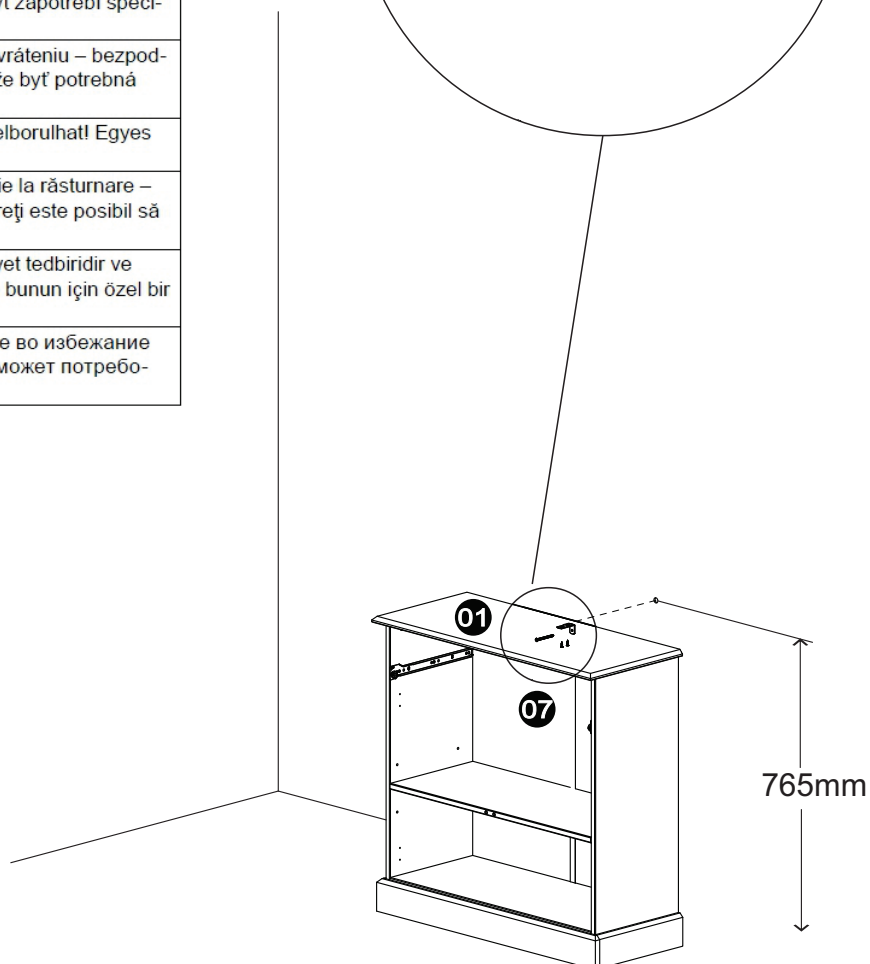
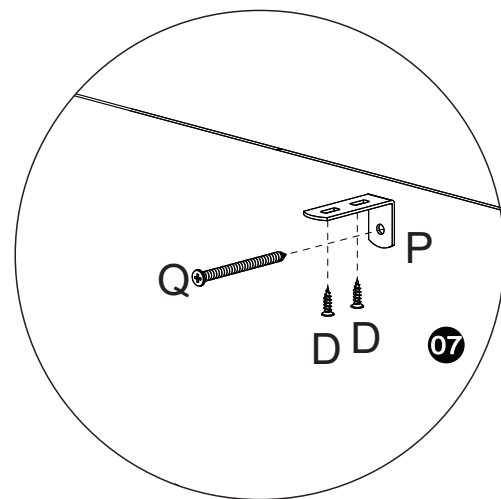

9

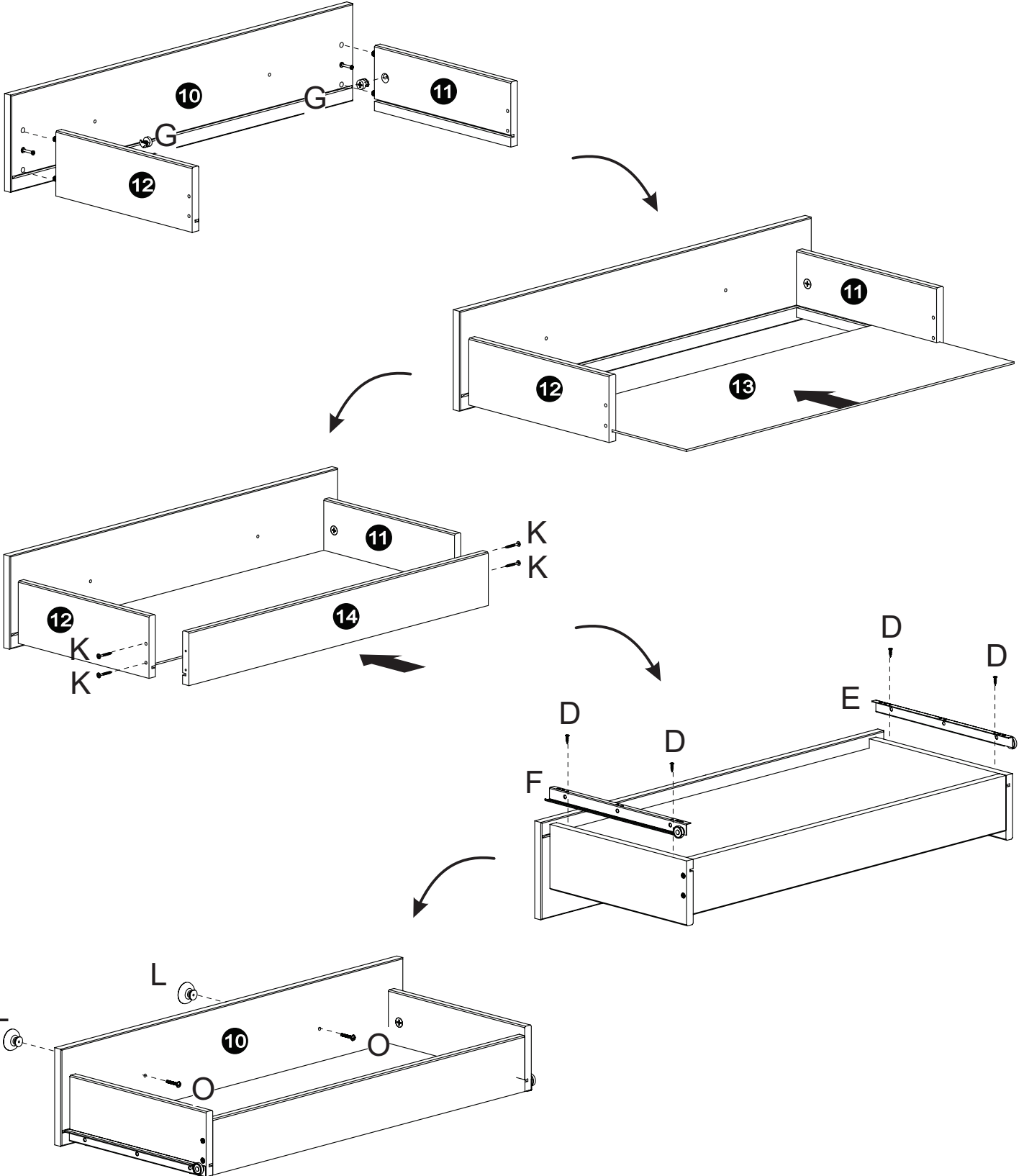
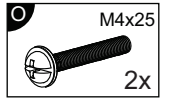
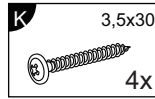
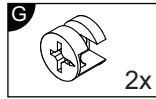
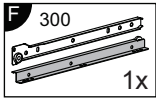
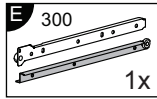
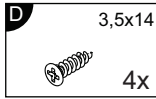

10

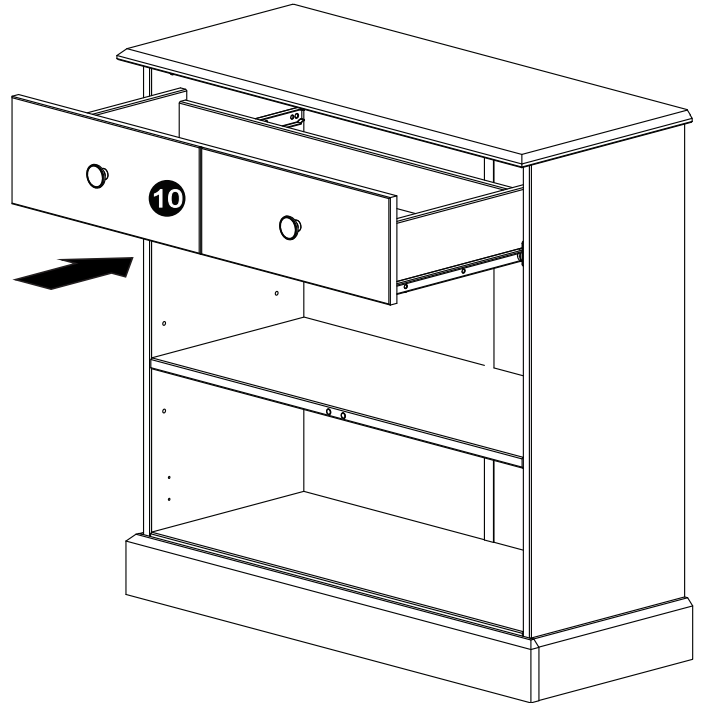
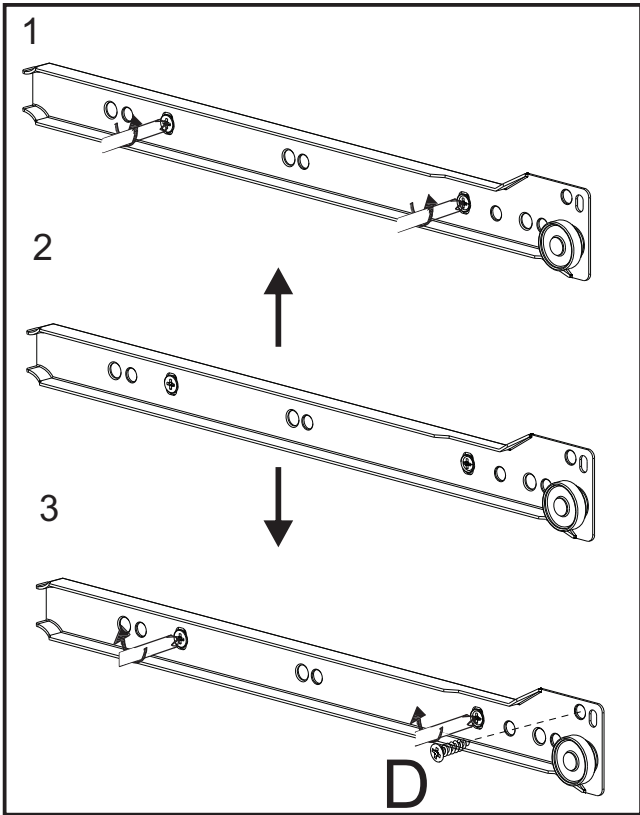
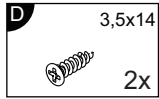

11

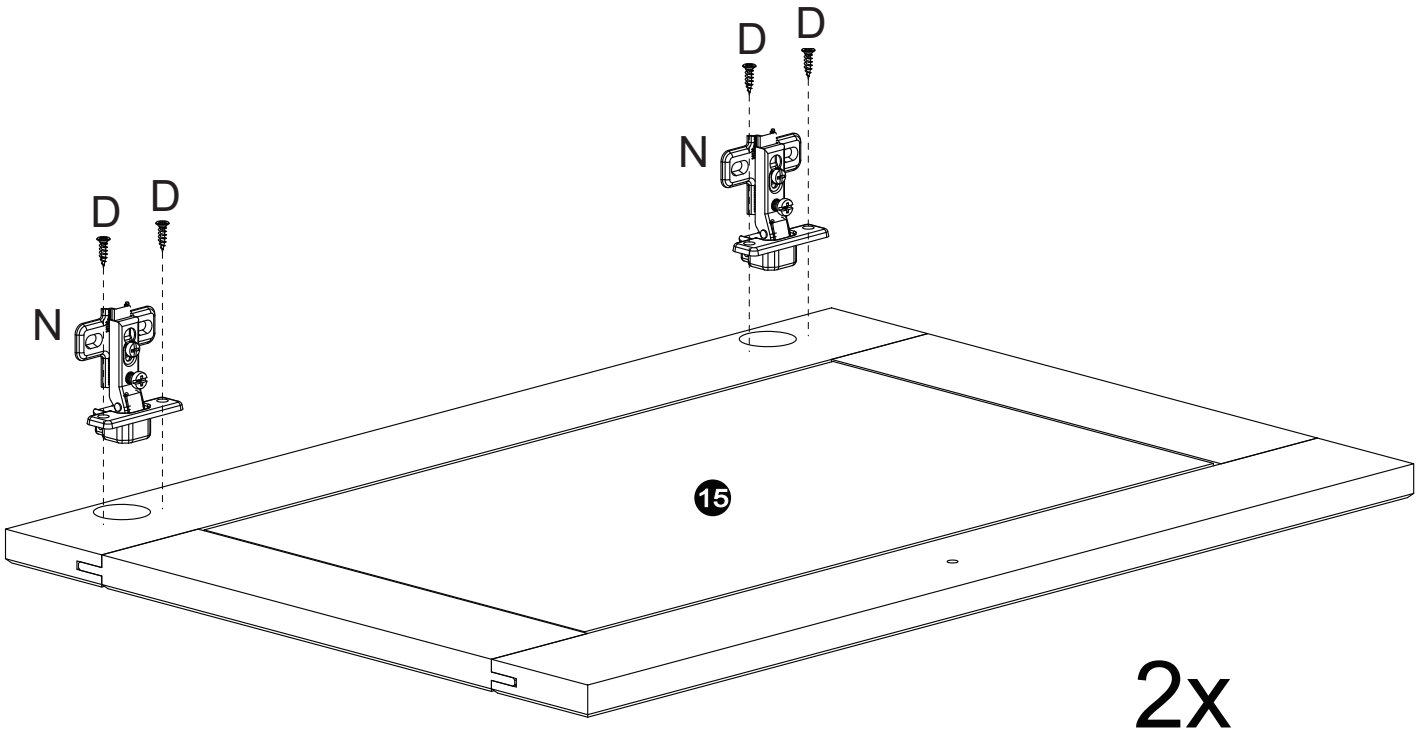
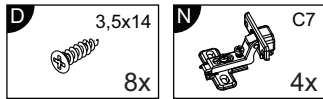

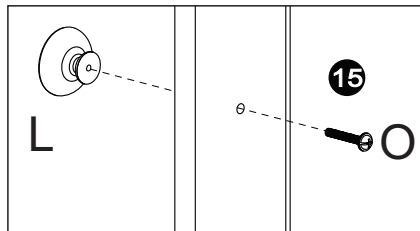
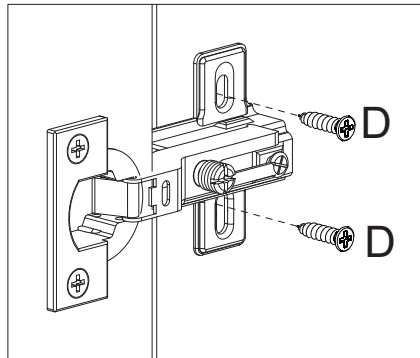
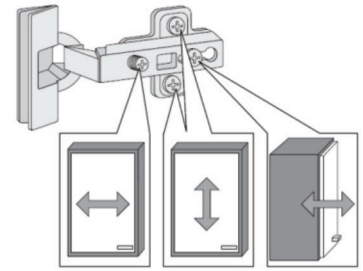
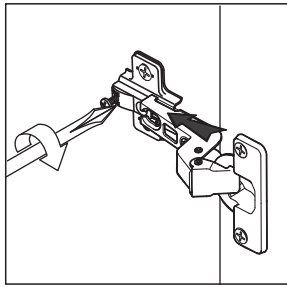

Türen einstellen (Scharniere justieren)
Adjusting the doors (adjusting the hinges)

Régler les portes (ajuster les charnières)

Sistemare le porte (regolare le cerniere)

Deuren instellen (scharnieren afstellen)

Nastawić drzwi (wyregulować zawiasy)

Vyrovnejte dvířka (seřid'te závěsy)

Nastavenie dverí (nastavenie závesov)

Állítsa be az ajtókat (állítsa be a zsanérokat)

Reglare ușii (ajustare balamale)

Kapıların ayarlanması (mentşelerin seviye ayarı)

Регулировка Дверей (регулировка шарнира)

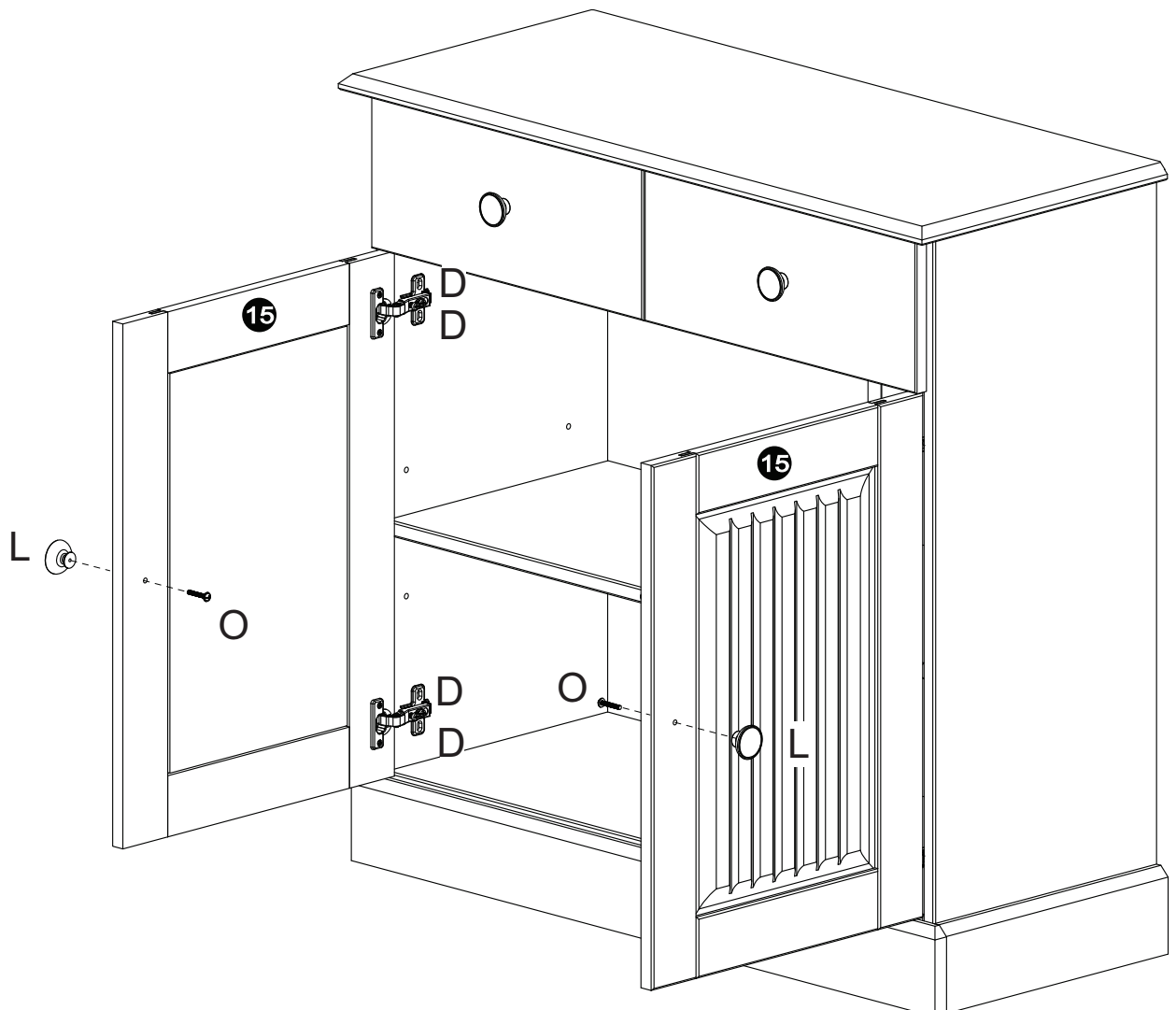

Mille 3026

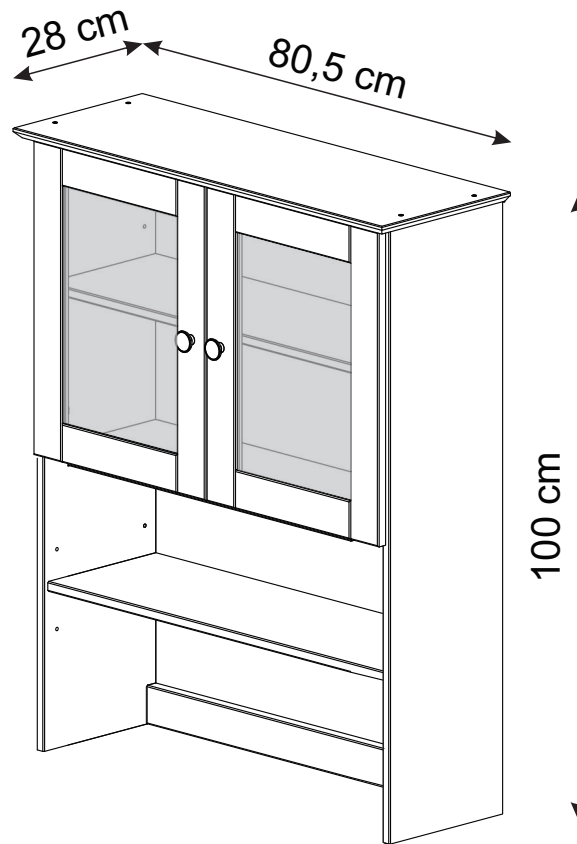



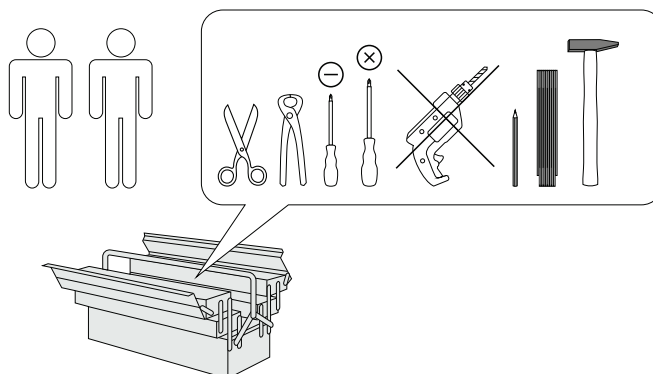





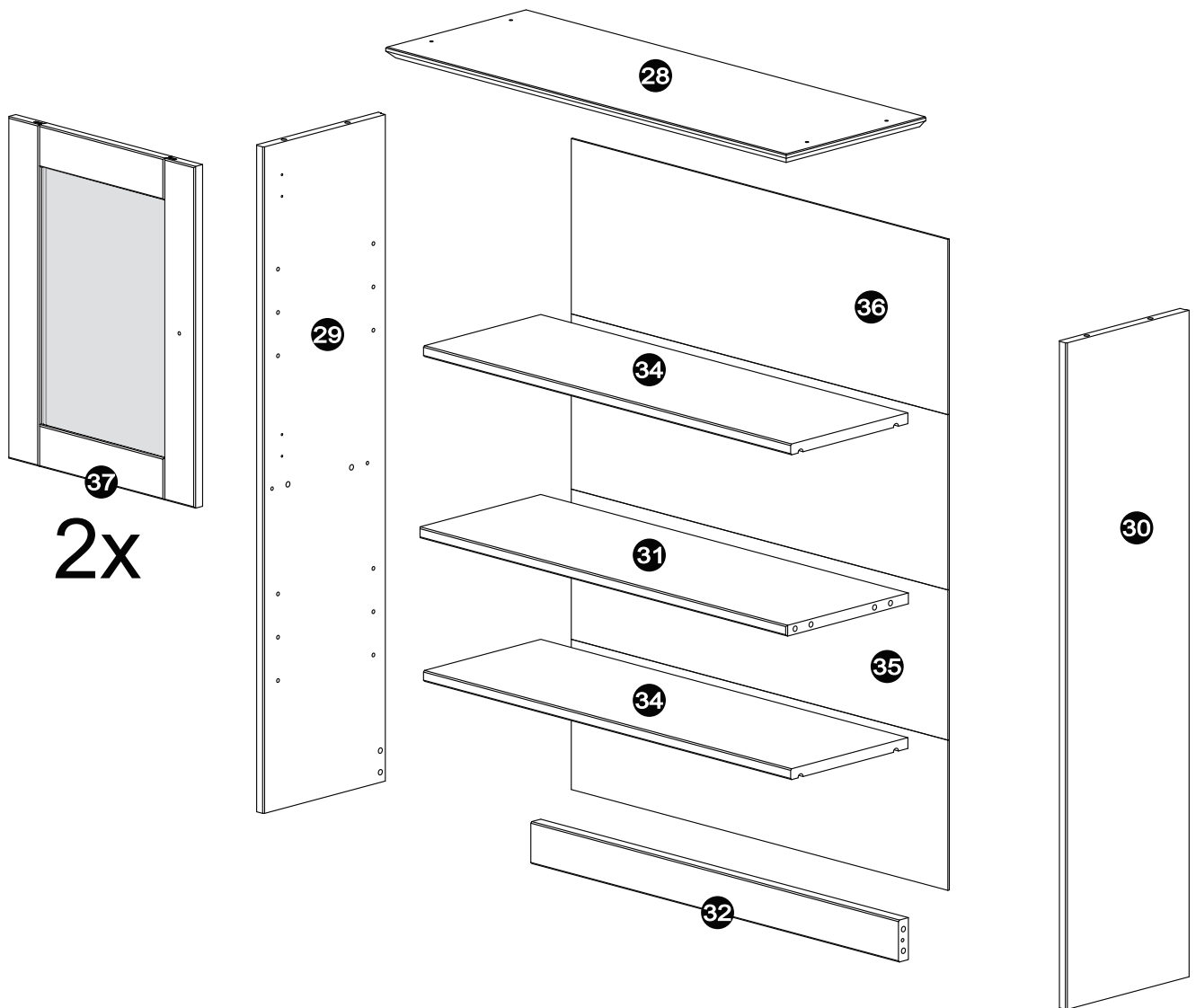
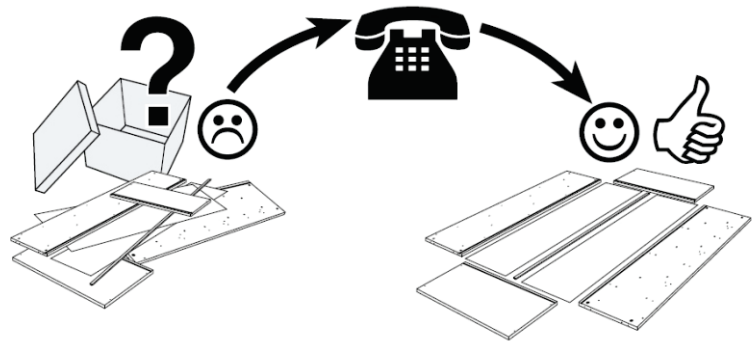
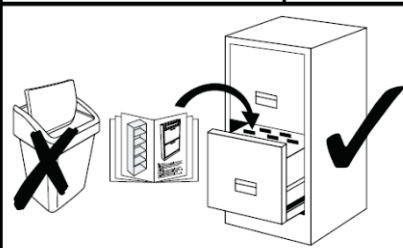





- | | |
|-------------------------------------------------|---------------------------------------------|
| (D) Montageanleitung
3026 | (GB) Assembly instructions
3026 |
| (FR) Notice de montage
3026 | (IT) Istruzioni di montaggio
3026 |
| (NL) Handleiding voor de montage
3026 | (PL) Instrukcja montażu
3026 |
| (CZ) Montážní návod
3026 | (SK) Návod na montáž
3026 |
| (HU) Szerelési útmutató
3026 | (RO) Instrucțiuni de montaj
3026 |
| (TR) Montaj talimatı
3026 | (RU) Инструкция по монтажу
3026 |



**Service • Assistenza • Dienstverlening • Serwis
Servis • Szerviz • Сервисная служба**

Name • Nom • Nome • Naam • Nazwa • Jméno • Názov • Név • Denumire • Isim • Название	
Nr. • No. • N° • Номер • Č • Sz	
Typ • Type • Tip • Típus • Tipo • Тип	
	



A  12x	B  4x	C  8x	D  24x	E  4x	F  2x	G  4x	H  6x	I  37x
J  5x	K  2x	L  1x	M  1x	N  2x				

1

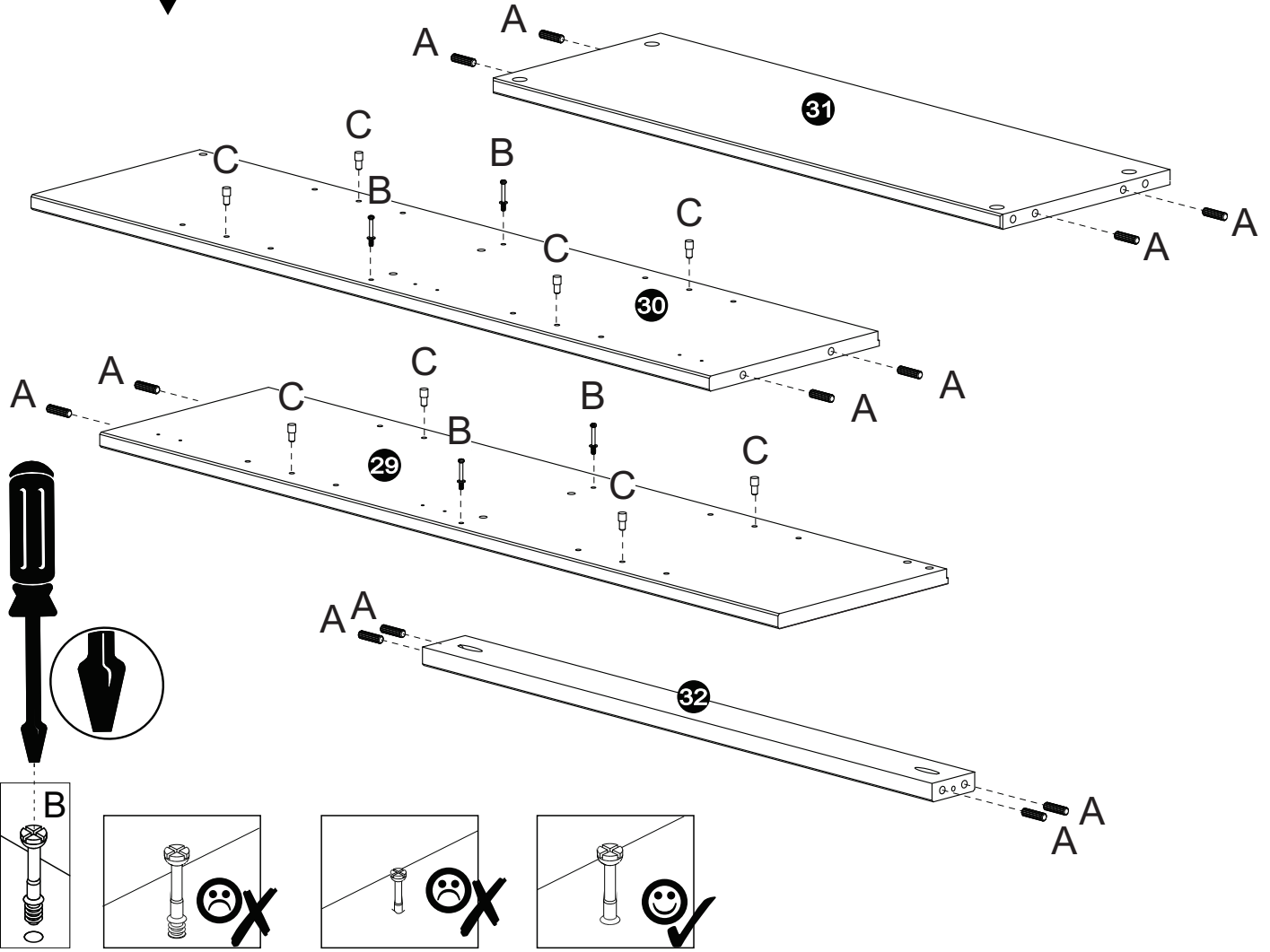
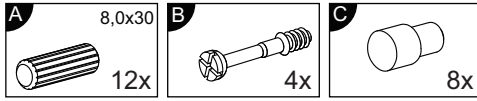

2

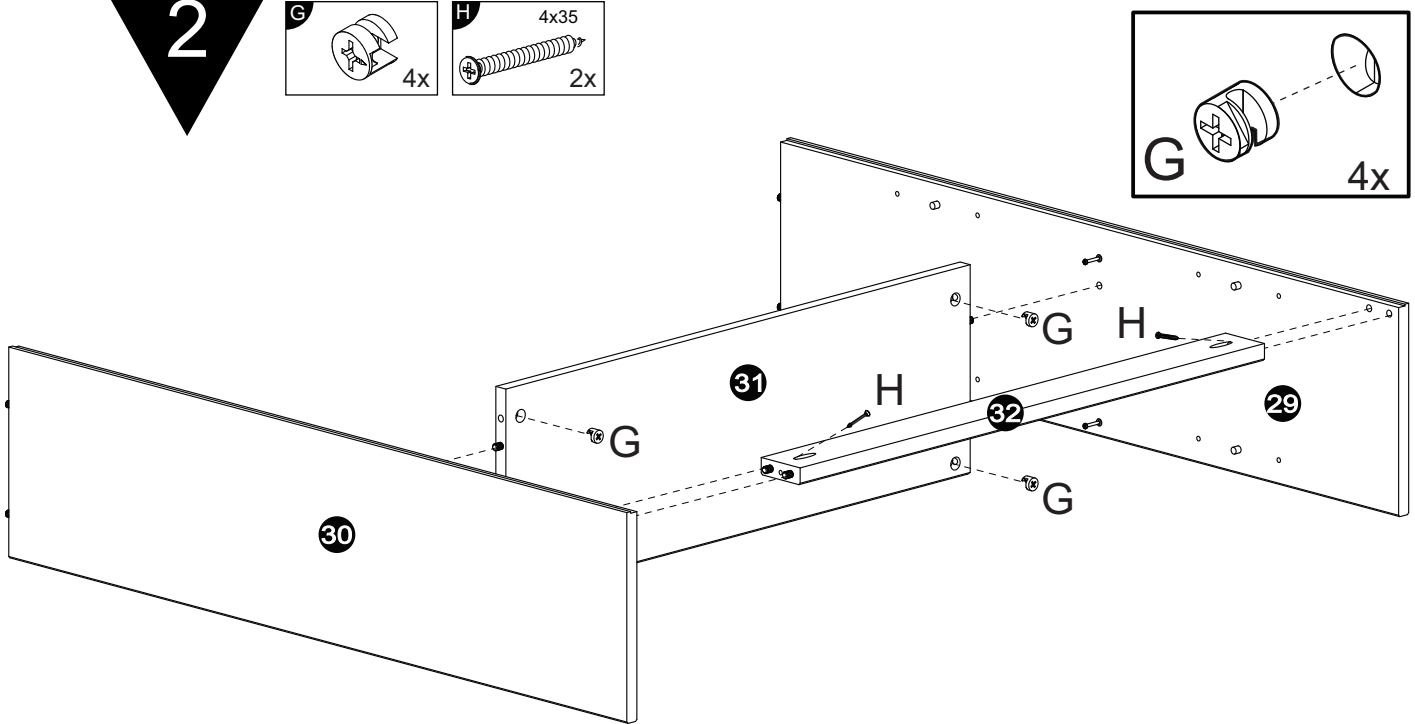
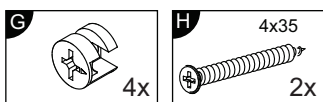

3

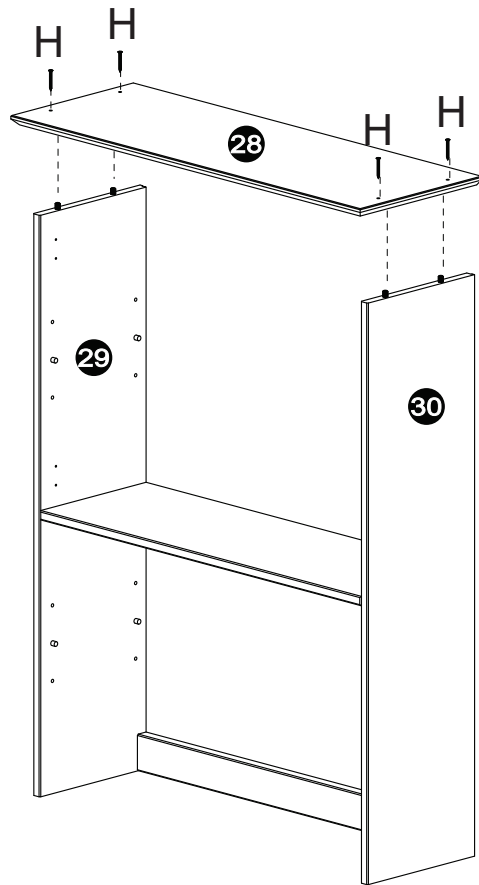
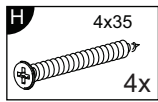

4

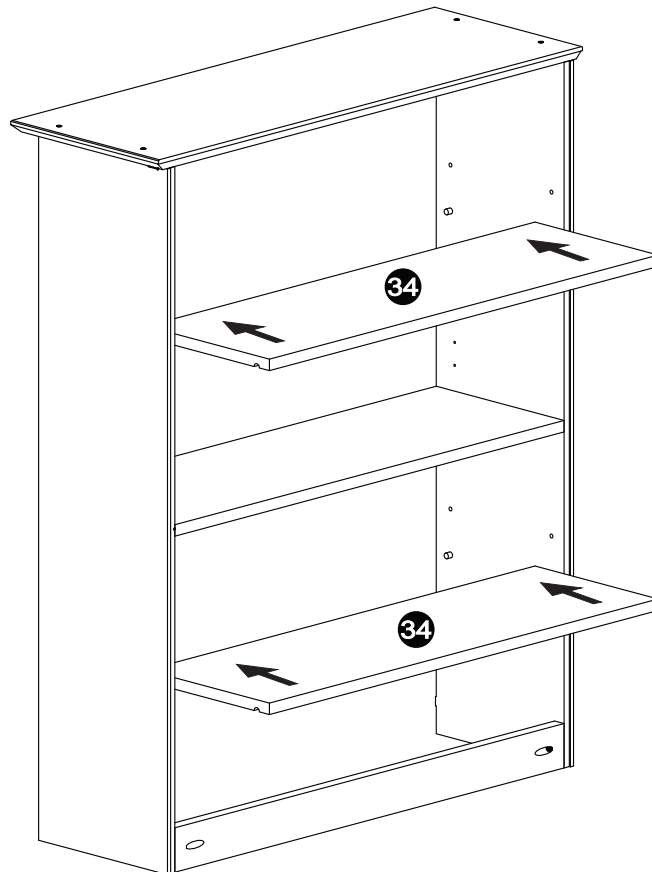

5

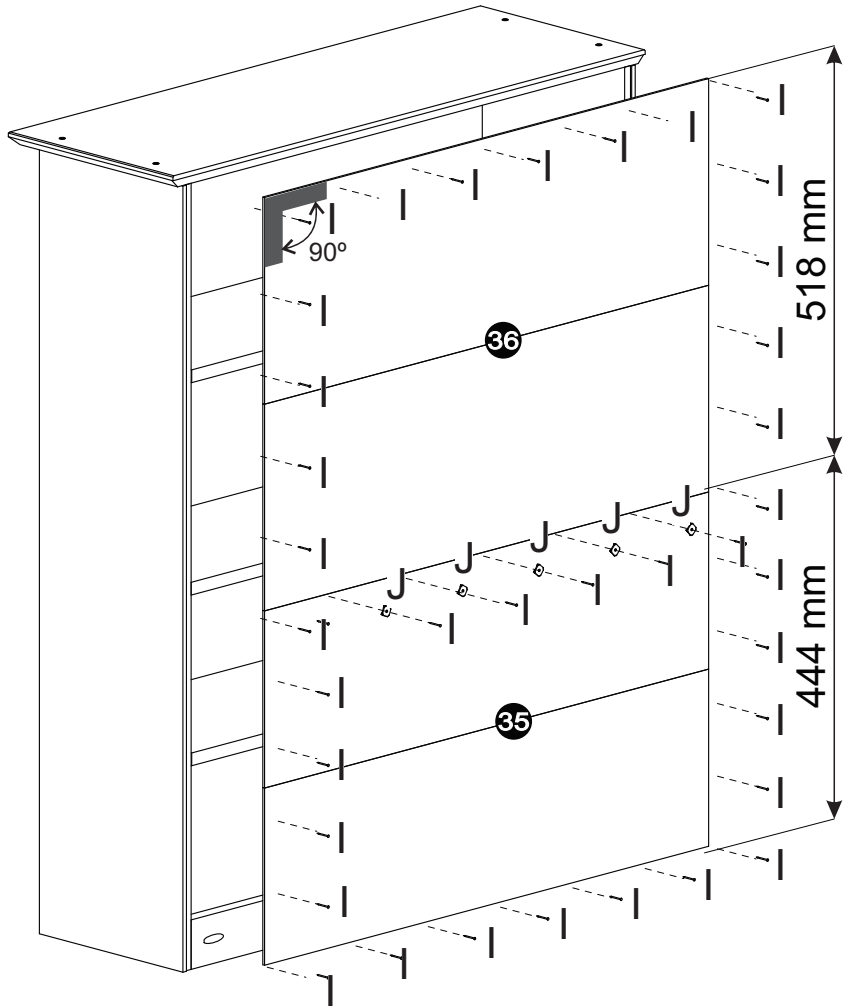
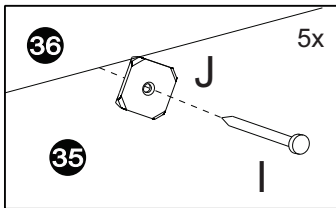
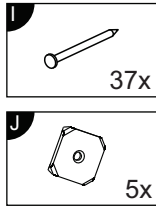

6

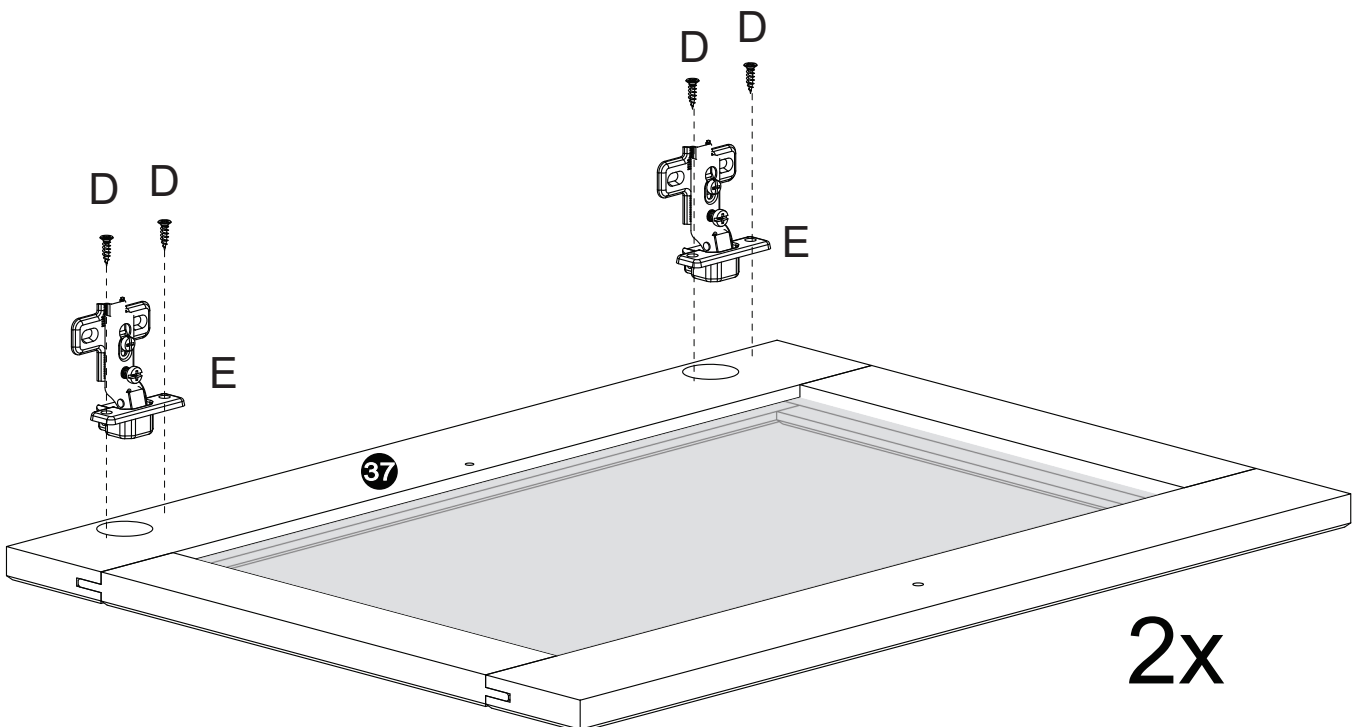
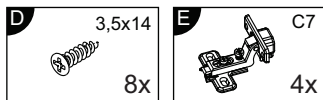

7

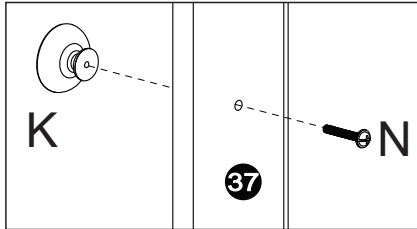
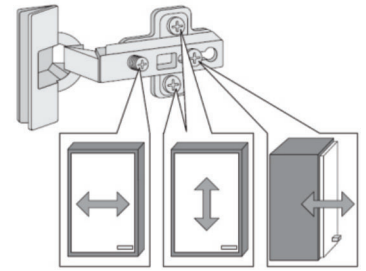
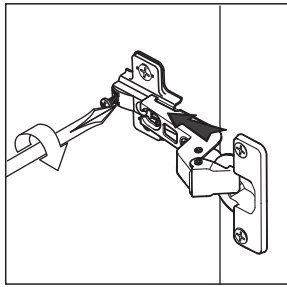
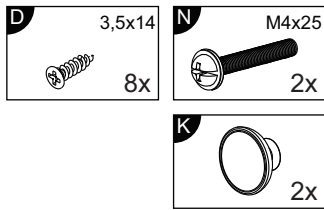

Türen einstellen (Scharniere justieren)
 Adjusting the doors (adjusting the hinges)
 Régler les portes (ajuster les charnières)
 Sistemare le porte (regolare le cerniere)
 Deuren instellen (scharnieren afstellen)
 Nastawić drzwi (wyregulować zawiasy)
 Vyrovnajte dvířka (seřid'te závěsy)
 Nastavenie dverí (nastavenie závesov)
 Állítsa be az ajtókat (állítsa be a zsanérokat)
 Reglare ușii (ajustare balamale)
 Kapıların ayarlanması (menteselerin seviye ayarı)
 Регулировка Дверей (регулировка шарнира)

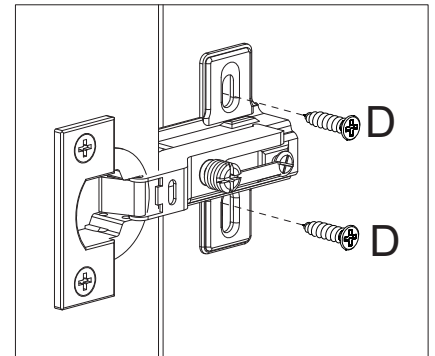
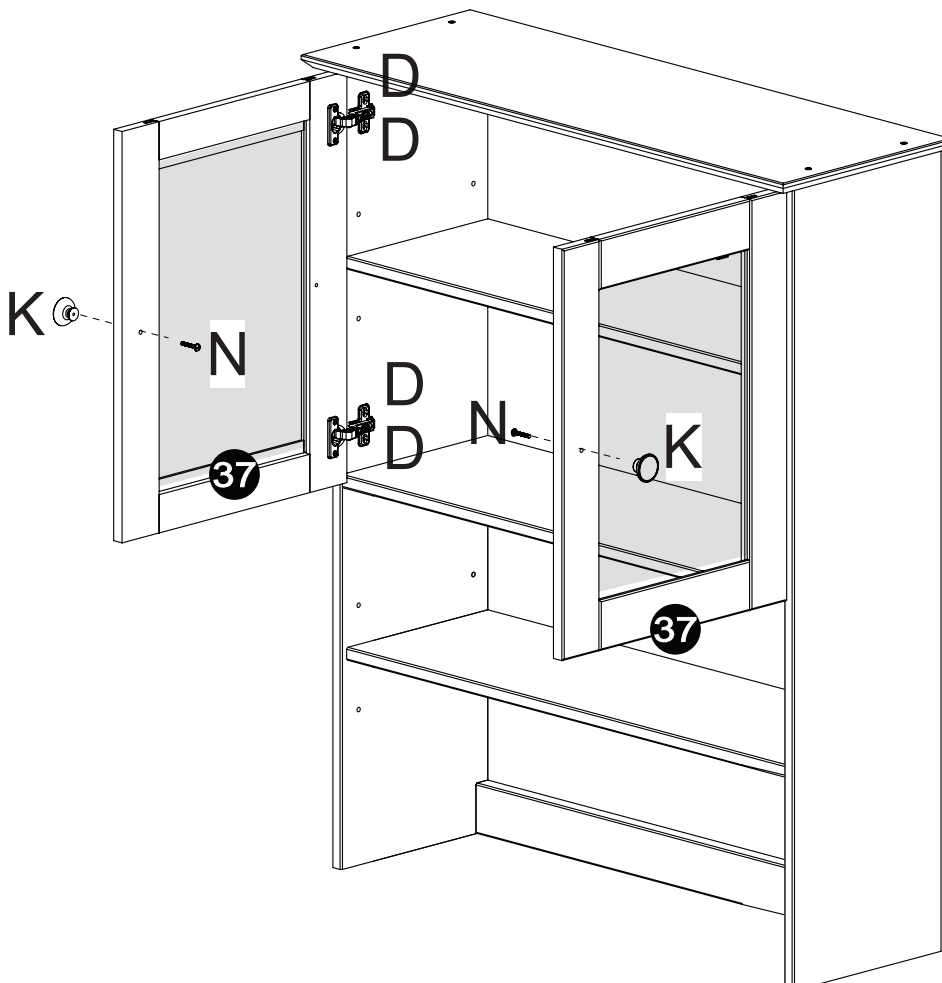

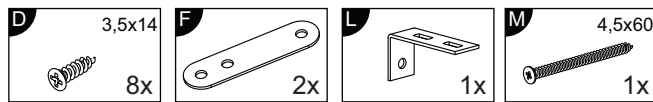

⚠ Achtung • Attention • Attenzione Opgelet • Uwaga • Pozor • Figyelem Atenție • Dikkat • Внимание ⚠	
(D)	Wandbefestigung dient als Kippschutz – unbedingt anbringen! Bei einigen Wandtypen kann ein Spezialdübel erforderlich sein!
(GB)	The wall fastening serves to prevent tipping – be absolutely sure to mount it! For certain wall types, a special wall plug may be necessary!
(FR)	La fixation murale sert de protection contre le basculement – à installer impérativement ! Pour certains types de murs il faut des chevilles spéciales !
(IT)	Il fissaggio alla parete serve da protezione anti-ribaltamento – attaccarla assolutamente! Per alcune strutture di parete può essere necessario un tassello speciale!
(NL)	Bevestiging aan de muur dient als kantelbescherming – zeker en vast bevestigen! Bij enkele muurtypes is een speciale plug misschien vereist!
(PL)	Mocowanie do ściany jest jednocześnie zabezpieczeniem przed przewróceniem – koniecznie zamontować! Do niektórych rodzajów ścian koniecznie zastosować specjalne kolki mocujące.
(CZ)	Montáž na stěnu slouží jako ochrana proti převrnutí – bezpodmínečně umístěte! U některých typů stěn může být zapotřebí speciální hmoždinka!
(SK)	Upevnenie na stenu slúži ako ochrana proti prevráteniu – bezpodmienečne použite! Pre niektoré druhy stien môže byť potrebná špeciálna hmoždinka!
(HU)	A terméket a falhoz kel rögzíténi, különben az felborulhat! Egyes faltípusoknál speciális tiplít kell használni!
(RO)	Sistemul de fixare la perete servește ca protecție la răsturnare – de montat obligatoriu! Pentru unele tipuri de pereți este posibil să fie necesar un diblu special!
(TR)	Duvardaki sabitleme, devrilmeye karşı bir emniyet tedbiridir ve mutlaka monte edilmelidir! Bazı duvar tiplerinde bunun için özel dübel gerekli olabilir!
(RU)	Обязательно установите крепление на стене во избежание опрокидывания! Для некоторых типов стен может потребоваться специальный дюбель!

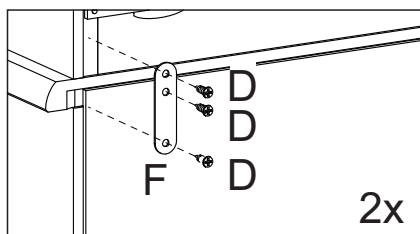
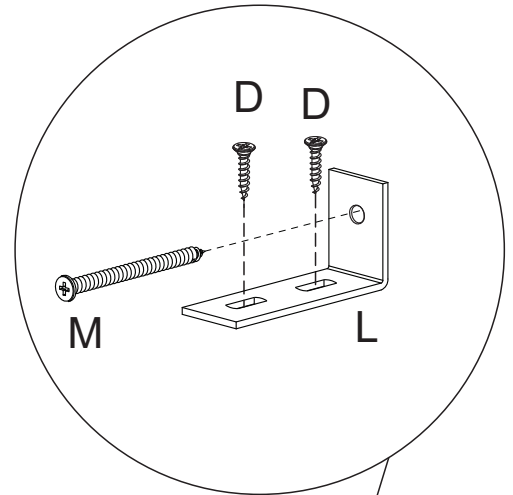

3023

1815mm

D+F